



DellTM PowerEdgeTM 4400 Systems User's Guide

[Safety Instructions](#)

[Preface](#)

[Introduction](#)

[Using the *Dell OpenManage Server Assistant* CD](#)

[Installing and Configuring SCSI Drivers](#)

[Using the System Setup Program](#)

[Using the Resource Configuration Utility](#)

[Technical Specifications](#)

[I/O Ports and Connectors](#)

[Maintaining the System](#)

[Regulatory Notices](#)

[Warranty, Return Policy, and Year 2000 Statement of Compliance](#)

[Glossary](#)

Model SML

**Information in this document is subject to change without notice.
© 1999 Dell Computer Corporation. All rights reserved.**

Reproduction in any manner whatsoever without the written permission of Dell Computer Corporation is strictly forbidden.

Trademarks used in this text: *Dell*, the *DELL* logo, *Dell OpenManage*, and *PowerEdge* are trademarks and *DellWare* is a service mark of Dell Computer Corporation; *Intel*, *1960*, and *Pentium* are registered trademarks and *MMX*, *Xeon*, and *Intel386* are trademarks of Intel Corporation; *Microsoft*, *Windows*, *MS-DOS*, and *Windows NT* are registered trademarks of Microsoft Corporation; *Novell* and *NetWare* are registered trademarks of Novell, Inc.; *ASPI* is a registered trademark of Adaptec, Inc.; *VESA* is a registered trademark and *VL-Bus* is a trademark of Video Electronics Standards Association; *Adobe* is a trademark of Adobe Systems Incorporated, which may be registered in certain jurisdictions; *OS/2* is a registered trademark of International Business Machines, Inc.

Other trademarks and trade names may be used in this document to refer to either the entities claiming the marks and names or their products. Dell Computer Corporation disclaims any proprietary interest in trademarks and trade names other than its own.

Initial release: 10 Sep 1999

Last revised: 4 Nov 1999

[Back to Contents Page](#)

Using the *Dell OpenManage Server Assistant* CD: Dell™ PowerEdge 4400 Systems User's Guide

[Overview](#)

[Utility Partition](#)

[Starting the *Dell OpenManage Server Assistant* CD](#)

[Video Driver](#)

[Navigating the CD](#)

[Asset Tag Utility](#)

[Using the Setup Modes](#)

Overview

The *Dell OpenManage Server Assistant* CD contains utilities, diagnostics, documentation, drivers, and other items that can help you configure a PowerEdge 4400 system to best meet your needs. Some of the functions available on the *Dell OpenManage Server Assistant* CD are also available on a bootable utility partition that is installed on your hard-disk drive. This section describes how to use the *Dell OpenManage Server Assistant* CD. It also describes the utility partition and its options and provides instructions for reinstalling the partition (if necessary).

Starting the *Dell OpenManage Server Assistant* CD

The Dell OpenManage Server Assistant application program has two modes of operation: a *setup mode* for setting up and configuring the PowerEdge 4400 system, creating diskettes, and viewing information and documents, and a *service mode* for creating diskettes and viewing information and documents.

In both setup mode and service mode, the **Dell OpenManage Server Assistant** main page gives you the option to choose one of the supported languages as the language for the screen text and online documentation. You can choose a language at any time from the main screen.

Setup Mode

To setup your system, as well as access the utilities, drivers, and other items available on the *Dell OpenManage Server Assistant* CD, insert the *Dell OpenManage Server Assistant* CD into your CD-ROM drive, and turn on or reboot the system. The **Dell OpenManage Server Assistant** main page appears.

If the CD does not boot, verify that the **Boot Device Priority** must be set to **CD-ROM Drive** in the System Setup program.

See "[Using the System Setup Program](#)" for more information.

Service Mode

You can access the online system documents, system setup instructions, frequently asked questions, and server product information on any desktop or server system that has Microsoft® Internet Explorer 4.0 (or later). When you insert the CD in a system that uses the Microsoft Windows NT® operating system, the system automatically starts the browser software and displays the **Dell OpenManage Server Assistant** main page.

Navigating the CD

The *Dell OpenManage Server Assistant* CD utilizes a standard Web browser interface. To navigate the CD, click the mouse on the various icons and text hyperlinks.

Click the **Back** icon to return to the previous page. Click the **Exit** icon to exit the program. Exiting the program causes the system to reboot to the standard operating-system boot partition.

Using the Setup Modes

If you purchase a system that does not have an operating system preinstalled by Dell, or if you reinstall an operating system at a later date, you should use either the **Express Setup** or **Custom Setup** option to configure your system.

Express Setup

Dell recommends **Express Setup** for most situations. The *Dell OpenManage Server Assistant* CD guides you through the operating system setup and configuration process. If a Dell PowerEdge Expandable RAID Controller (PERC) host adapter is installed, the Dell redundant arrays of independent disks (RAID) utility configures the drives. If the drive does not have a utility partition, one is created. The program prompts you to select the operating system used on the drive and leads you through a step-by-step process to install the operating system.

To start **Express Setup**, perform the following steps:

1. Click the **SETUP** icon at the top of the screen.
2. Click **Express Setup**.
3. Follow the directions on the screen to complete the installation and configuration.

Express Setup allows you to perform the following tasks:

- 1 Create the Express Setup diskette
- 1 Enter operating system and hard-disk drive information
- 1 Configure the operating system
- 1 Perform setup

Custom Setup

Use **Custom Setup** if your system has special configuration requirements.

To start **Custom Setup**, perform the following steps:

1. Click the **SETUP** icon at the top of the screen.
2. Click **Custom Setup**.
3. Follow the directions on the screen to complete the installation and configuration.

Utility Partition

The utility partition is a bootable partition on the hard-disk drive that provides some of the functions available on the *Dell OpenManage Server Assistant* CD. Most of the application programs found on the CD are contained in the utility partition. When implemented, the partition boots and provides an executable environment for the partition's utilities. When the utility partition is not booted, it is designated as a non-MS-DOS® partition.

 **NOTE:** The utility partition provides only limited MS-DOS functionality and cannot be used as a general-purpose MS-DOS partition.

To start the utility partition, turn on or reboot the system. During the power-on self-test (POST), the following message appears:

Press <F10> to enter Utility Mode

The utility partition provides a text-based interface from which you invoke the partition's utilities. Menu options and the associated help are displayed in the currently selected language (specified via a menu option). To select a menu option, you can either use the arrow keys to highlight the option and press <Enter>, or type the number of the menu option. To return to the previous menu, press <Esc> or select the **Back** menu option. To exit the utility partition, press <Esc> from the **Main Menu**. Exiting the utility from setup mode causes the system to reboot to the standard operating-system boot partition.

[Table 1](#) provides a sample list and explanation of the options that appear on the utility partition menu even when the *Dell OpenManage Server Assistant* CD is not in the CD-ROM drive. The options displayed on your system may vary depending on the configuration.

 **NOTE:** Although most options are available from both the *Dell OpenManage Server Assistant* CD and the utility partition, some options or features, such as those for accessing online documentation, are available only from the CD.

Table 1. Utility Partition Main Menu Options

Option	Description
Choose a Language:	
German, English, Spanish, French	Allows you to select the language in which menus and messages are displayed.
Run System and Configuration Utilities:	
Run Resource Configuration Utility	Runs the RCU.
Run Dell System Diagnostics	Runs the system hardware diagnostics.
Run RAID Configuration Utility	Runs the RAID controller configuration utility if a RAID controller card is present on your system.

Create Diskettes:	
Create Blank, Formatted diskette	Creates a blank, formatted diskette.
Create Utility and Diagnostics diskettes:	
Create Resource Configuration Utility diskettes	Creates a bootable diskette for running the RCU. The RCU detects expansion cards and slots, enabling automatic configuration.
Create PERC 2 Configuration Utility diskette	Creates a bootable diskette for running the RAID controller configuration utility for the specified Dell RAID host adapter card. The RAID configuration utility provides an alternative method for configuring the card.
Create Diagnostics diskettes	Creates a set of diskettes from which the hardware diagnostics can be run. The first diskette in the set is bootable.
Create Asset Tag diskette with CD-ROM	Creates a bootable diskette with CD-ROM support from which utilities, such as the Asset Tag utility, can be run.

NOTES: The options displayed on your system are dependent on your system configuration and may not include all of those listed here.

For the full name of an abbreviation or acronym used in this table, see the "[Glossary](#)."

Running the System Diagnostics

You can run the system diagnostics from the utility partition or from a diskette, but not from the *Dell OpenManage Server Assistant* CD. To run the diagnostics from a diskette, create a diagnostics diskette from the the Dell OpenManage Server Assistant CD.

The system hardware diagnostics are described in "Running the Dell Diagnostics" in the *Dell PowerEdge 4400 Systems Installation and Troubleshooting Guide*.

Video Driver

 *NOTES: The video display for the Microsoft Windows NT Server 4.0 operating system must be set up with a resolution of 640 x 480 at installation.*

Windows NT Server 4.0 Service Pack 4 must be installed before you can use the updated video driver for the ATI Rage video controller.

You need to install the video driver for the operating system you install on your system unless they were installed by Dell.

Installing Video Drivers for Windows NT Server 4.0

 *NOTE: Video drivers must be reinstalled after every installation of Windows NT Server 4.0 Service Pack 3 (or later versions). Use this procedure only if you do not use **Express Setup** to install your operating system.*

First, create a driver diskette by performing the following steps:

1. Select **Create Diskettes** from the **Dell OpenManage Server Assistant** setup page.
2. Select the system for which to create the driver diskette.
3. Create the video-controller driver diskette for Windows NT 4.0.

Then install the video driver by performing the following steps:

1. Start Windows NT.
2. Log in as the administrator or as a user with administrative privileges.

For information on system administration, see the reference documentation for Windows NT.

3. Click the **Start** button, point to **Settings**, and click **Control Panel**.
4. Double-click the **Display** icon.

The **Display Settings** window appears.

5. Select the **Settings** tab.
 6. Click **Display Type** and then click **Change** in the **Adapter** box.
A list of available video drivers is displayed.
 7. Click **Have Disk**.
 8. Insert the video driver installation diskette into the diskette drive; then click **OK** in the **Install From Disk** window.
 9. Make sure that **ATI Rage Ilc** (the default) is selected in the video driver list, and click **Install**.
The **Installing Drivers** dialog box appears.
 10. Click **Yes** to proceed.
After the files are copied from the diskette, Windows NT prompts you to restart your system. Click **OK** and close all open windows.
 11. Remove the video drivers diskette from the diskette drive and restart Windows NT.
 12. Click the **Start** button, point to **Settings**, and click **Control Panel**.
 13. Click the **Display** icon.
The **Display Settings** window appears.
 14. Set the desired resolution, number of colors, and refresh rate.
-

Asset Tag Utility

The Asset Tag utility allows you to enter an asset tag number for your system.

 **NOTE:** The Asset Tag utility works only on systems running MS-DOS.

Using the Asset Tag Utility

To create the Asset Tag utility diskette and boot the system, perform the following steps:

1. If you have not already done so, create a bootable Asset Tag utility diskette from the *Dell OpenManage Server Assistant CD* using the **Create Asset Tag diskette with CD-ROM** option.
2. Insert the diskette into the diskette drive and reboot the system.

 **NOTE:** The Asset Tag utility diskette contains CD-ROM drivers that provide access to the CD-ROM drive when you boot from the diskette.

After you boot the system with the Asset Tag utility diskette, you can use the Asset Tag utility to enter an asset tag number that you or your organization assigns to the system. You can also use the Asset Tag utility to reenter the system's service tag number if that becomes necessary.

Assigning and Deleting an Asset Tag Number

An asset tag number can have up to ten characters; any combination of characters, excluding spaces, is valid.

To assign or change an asset tag number, perform the following steps:

1. Perform the steps in "[Using the Asset Tag Utility](#)."
2. Type `asset` and a space followed by the new number.
3. Press <Enter>.

For example, type the following command line and press <Enter>:

```
asset 1234567890
```

4. When you are prompted to verify the asset tag number, type `y` and press <Enter>.
The system then displays the new or modified asset tag number and the service tag number.

To delete the asset tag number without assigning a new one, type `asset /d` and press <Enter>.

Table 2 lists the command-line options you can use with the Asset Tag utility. To use one of these options, type `asset` and a space followed by the option.

Table 2. Asset Tag Command-Line Options

Asset Tag Option	Description
/d	Deletes the asset tag number
/?	Displays the Asset Tag utility help screen

[Back to Contents Page](#)

[Back to Contents Page](#)

Using the Resource Configuration Utility: Dell™ PowerEdge™ 4400 Systems User's Guide

[Overview](#)

[Advanced Menu](#)

[Starting the RCU](#)

[Resolving Resource Conflicts](#)

[Main Menu](#)

Overview

The Resource Configuration Utility (RCU) is used to tell the system what expansion cards are installed and which expansion slots they occupy. With this information, the system automatically configures Plug and Play expansion cards and Peripheral Component Interconnect (PCI) expansion cards. Before your system was shipped from Dell, a technician used the RCU to enter the correct information for the expansion cards initially installed in your computer.

The RCU also monitors the resources required by any installed PCI expansion card. After installing or moving a PCI expansion card, you should run the RCU to update the system's database of available system resources stored in nonvolatile random-access memory (NVRAM).

NOTICE: Whenever you make changes to the System Setup program or change settings for integrated devices, you must run the RCU, make any necessary changes, and save the system configuration information. Failure to do so may cause resource conflicts between PCI devices (such as PCI expansion cards, the integrated video controller, or the integrated small computer system interface [SCSI] host adapter). See "[Configuring Expansion Cards](#)" for more information about how PCI devices are configured based on settings in the RCU.

Configuring Expansion Cards

The RCU is PCI-aware and can also be used to configure PCI expansion cards. Configuration information for PCI expansion cards is contained within the card, so no additional .cfg file is required. You should run the RCU after installing or moving a PCI expansion card to keep the system's database of available resources accurate.

How to Run the RCU

The RCU is included on the *Dell OpenManage Server Assistant* CD shipped with your system. This CD includes an RCU directory that contains the main program.

You can run the RCU directly from the CD or from a diskette that you create using the CD's main menu. Dell recommends that you run the RCU from a diskette because the RCU is not compatible with all operating systems. Also, using a diskette to run the utility allows you to copy any system configuration changes to the diskette for safekeeping. See "[Using the Dell OpenManage Server Assistant CD](#)" for instructions on creating an RCU diskette.

PCI expansion cards do not require a configuration file. The PCI configuration utility in ROM automatically uses the information maintained by the RCU to assign resources for PCI expansion cards.

When to Run the RCU

Whenever you add or remove expansion cards, you must run the RCU to ensure that no two cards attempt to use the same resources (such as interrupt request [IRQ] lines).

After you have run the RCU and it has configured all your expansion cards, you can use the utility to lock the configuration of your PCI expansion cards so that they are always assigned the same resources.



NOTE: If your system detects a card configuration problem during operation, you receive a warning message directing you to run the RCU to correct the problem.

Making Selections in the RCU

The RCU uses menus to guide you through the configuration process. The menus and their options are accessed through keyboard commands.

To make a menu selection, press the up- or down-arrow key to highlight the desired option, and then press <Enter>. In the **Help** menu or **Advanced** menu, you can also select an option by pressing the key that corresponds to the highlighted letter in the selection list.

To scroll up or down a screen, press the <Page Up> or <Page Down> key, respectively.

Using Online Instructions

The RCU has online instructions for each of its procedures. If you need help at any time, press <F1> to see a help screen that offers more details about the task you are doing.

Starting the RCU

If you are running the RCU from your hard-disk drive, remove any terminate-and-stay-resident (TSR) programs from memory before starting the utility. These programs take up space in system memory even when they are not running, thus reducing the amount of memory available to the RCU. See the documentation that accompanied these programs for instructions on removing them from memory.

If you start the utility and there is not enough memory to run it, a message is displayed. If you receive such a message, run the utility from a diskette.

Perform the following steps the first time you use the RCU. Later, if a card is added, removed, or repositioned, you must follow the procedure described in "[Step 2: Add or Remove Boards](#)."

1. To run the program from a diskette, insert the RCU diskette that you created from the CD into drive A. Then either turn on your computer or reboot it by pressing the <Ctrl><Alt> key combination or the reset button.

To run the program from your hard-disk drive, switch to the `c:\rcu` subdirectory, type `sd` at the operating system prompt, and press <Enter>.

To run the program from the *Dell OpenManage Server Assistant* CD, restart the system from the CD. Select **Run RCU** from the CD's main menu.

2. When the **Welcome** screen appears, read the information on the screen and press <Enter>.

The **Main Menu** appears:

Main Menu

```
Learn about configuring your computer
Configure computer
Set date
Set time
Maintain system configuration diskette
Exit from this utility
```

The first option in the menu is already highlighted.

3. Press <Enter> to read the online overview of the RCU.

After reading the online overview, you are ready to use the program to configure your computer for any PCI expansion cards currently installed.

Main Menu

The following sections describe each of the menu options in the **Main Menu** and the submenus for those options.

Learn About Configuring Your Computer

The **Learn about configuring your computer** option presents an overview of the configuration process. As you finish reading a screen, press <Enter> to view the next screen. Press <F10> to return to the **Main Menu**.

Configure Computer

The **Configure computer** option takes you through the configuration process step by step. Use this option the first time you configure your system and every time you change your configuration through the RCU.

When you select **Configure computer**, the following menu appears on the screen:

```
Steps in configuring your computer
```

```
Step 1: Important resource configuration information
Step 2: Add or remove boards
Step 3: View or edit details
Step 4: Examine switches or print report
Step 5: Save and exit
```

Step 1: Important Resource Configuration Information

The **Step 1: Important resource configuration information** option uses seven information screens to explain the configuration process. After you read the first screen, press <Enter> to see the next one. When you finish reading all seven screens, press <Esc> to return to the **Steps in configuring your computer** menu.

To review the information screens at any time while you are in the RCU, press <F1> and select **Resource Configuration** from the Help menu.

Step 2: Add or Remove Boards

When you select the **Step 2: Add or remove boards** option, the RCU lists all the expansion slots in your computer. (You may have to press <Page Down> to view the entire list.)

If you copied a card's configuration file to your RCU diskette or to the RCU configuration subdirectory (**rcu**) on your hard-disk drive, the card name appears in the expansion slot in which the card is installed.

The first time you run the RCU, select **Step 2: Add or remove boards** to verify that the system has detected and acknowledged any expansion cards Dell installed when you purchased your system. Use this option whenever you add or remove an expansion card and every time you reposition a card from one expansion slot to another in your computer.

To add, reposition, or remove an expansion card, highlight the corresponding expansion slot and press <Ins> to add, <F7> to reposition, or to remove the card. The utility guides you through the steps required to add, reposition, or remove a card's configuration file within the RCU. If there are no resource conflicts, the system configuration information is saved to a system configuration (**.sci**) file when you exit the utility.

Repositioning an Expansion Card

Use the following procedure after a PCI expansion card is repositioned. See "[When to Run the Resource Configuration Utility](#)" for more detailed information.

1. [Start the RCU.](#)
2. At the **Main Menu**, select **Configure computer**.
3. At the **Steps in configuring your computer** menu, select **Step 2: Add or remove boards**.

A list of expansion slots and the cards in them appears on the screen.

4. Highlight the name of the card that you want to reposition, press <F7>, and follow the online instructions.
5. Press <F10>, select **Step 5: Save and exit**, and follow the online instructions to save the current system configuration information.

Remember to save a printout or written copy of the new information.

Removing an Expansion Card

Perform the following steps after you remove a PCI expansion card. See "[When to Run the Resource Configuration Utility](#)" for more detailed information.

1. [Start the RCU.](#)
2. At the **Main Menu**, select **Configure computer**.
3. At the **Steps in configuring your computer** menu, select **Step 2: Add or remove boards**.

A list of expansion slots and the cards installed in them appears on the screen.

4. Highlight the name of the card you want to remove, press , and follow the online instructions.
5. Press <F10>, select **Step 5: Save and exit**, and follow the online instructions to save the current system configuration information.

Remember to save a printout or written copy of the new information.

If there are no resource conflicts, the configuration information is saved to a system configuration (**.sci**) file when you exit the utility. If there is a resource conflict, you must resolve it before completing the configuration.

Step 3: View or Edit Details

The RCU lets you set a variety of system options through the **.sci** file. Through this file, you can notify the system of changes to your hardware and memory configuration, manage input/output (I/O) ports, and set other system operating parameters.

Some of the categories do not offer options, but reflect installed hardware that is detected by the system. These items are displayed for your information only; you cannot change them through the utility.

To display the list of system board options, perform the following steps:

1. [Start the RCU.](#)
2. At the **Main Menu**, select **Configure computer**.
3. At the **Steps in configuring your computer** menu, select **Step 3: View or edit details**.

A list of system board options appears on the screen. [Figure 1](#) shows settings typical for your system.

 **NOTE:** Whenever you add an expansion card to the computer, its presence is reflected by changes to the **System Board Options** screen.

4. To select a category on the list of system board options, press the up- or down-arrow key to highlight the category and press <Enter>.

A pop-up menu appears, listing the options for that category. To select an option, press the up- or down-arrow key to highlight the option and press <Enter>.

 **NOTES:** Several system board categories allow you to edit such resources as memory address, I/O ports, IRQs, and direct memory access (DMA) channels. It may be necessary to edit these resources to resolve a configuration conflict. To view the resource screen for any category, highlight the option and press <F6>.

The edit resources feature is intended for users who are technically knowledgeable. Do not change resource settings from their defaults if you do not understand how such a change will affect system performance.

While in the **Step 3: View or edit details** menu, you can press <F7> to enter the [Advanced](#) menu.

When you have finished making changes, perform the following steps to save the new system configuration information and exit the utility:

1. Press <F10>, and select **Step 5: Save and exit** from the **Steps in configuring your computer** menu.
2. Select **Save the configuration and restart the computer** from the menu that appears.

[Figure 1](#) shows the system board options that are available on the **View or edit details** screen.

Figure 1. View or Edit Details Screen (Example)

```
System - Dell System PowerEdge 4400
RS-232 COM Port 1.....IRQ 4 PORT 3F8h-3FFh
RS-232 COM Port 2..... IRQ 3 PORT 2F8h-2FFh
Parallel Port..... IRQ * PORT 378h-37Fh
Floppy Controller..... IRQ 6 PORT 30Fh-3Fh DMA 2
Mouse Controller..... Enabled

Embedded - PCI Multifunction Controller - Bus 1
PCI Function 1 ..... Enabled
PCI Function 2 ..... Enabled

Embedded - Adaptec AIC-7899 Dual Channel Ultra 160 SCSI Ctrlr
PCI Function 1 ..... Enabled
PCI Function 2 ..... Enabled

Embedded - Adaptec AIC-7880 Fast 20 SCSI Ctrlr
PCI Function 1 ..... Enabled

Embedded - PCI Universal (USB) Controller
PCI Function 3 ..... Enabled

Embedded - Intel Fast Ethernet LAN Controller
PCI Function 1 ..... Enabled

Embedded - PCI VGA Controller
PCI Function 1 ..... Enabled

Standard VGA Resources ..... Enabled
```

Step 4: Examine Switches or Print Report

The **Step 4: Examine switches or print report** option lists the required switch and jumper settings for each expansion card in your computer. To view the settings, highlight the card and press <Enter>.

Press <F7> to make a copy of or print the settings. If your computer is attached to a printer, you can print the information or copy it to a file.

Step 5: Save and Exit

The **Step 5: Save and exit** option allows you to save or cancel the configuration changes that you have made. When you select this option, follow the directions on the menu that displays.

If you save your changes, the utility saves the new configuration in your system's NVRAM and in a file on your RCU diskette. The utility automatically reboots your system.

If you cancel your changes, you can remain in the utility to make other changes or exit the utility without saving any changes.

Maintain System Configuration Diskette

Using the **Maintain system configuration diskette** option, you can create a backup copy of the **.sci** file or use a previously saved **.sci** file to reconfigure your system or to identically configure many other systems. You can also copy **.cfg** files and delete **.sci** and **.cfg** files from your RCU diskette, your diskette of **.cfg** files, or the configuration diskette(s) for any hardware option.

Exit From This Utility

The **Exit from this utility** option allows you to exit from the RCU and reboot your computer system.

Advanced Menu

The **Advanced** menu lets you lock or unlock cards in a configuration, view detailed information about the system, and maintain **.sci** files.

To see the **Advanced** menu, press <F7> while in the **Step 3: View or edit details** menu. The following menu appears:

```
Advanced menu
Lock/unlock boards
View additional system information menu
Set verification mode menu
Maintain SCI files menu
```

Highlight the menu category that you want and press <Enter>. Then follow the online instructions.

The following subsections describe each category.

Lock/Unlock Boards

When you lock an expansion card, the RCU cannot change the resources allocated to that card. Unlocking the card allows the system to change the resources automatically as new cards are added. The default setting for the **Lock/unlock boards** category is **Unlocked**. Dell recommends that you keep your cards unlocked so that the RCU can do its job properly.

 **NOTE:** The RCU ignores the **Lock/unlock boards** setting for the PCI host bridge and the PCI-to-PCI bridge devices.

View Additional System Information Menu

The RCU contains detailed information about the system board and the used and available resources. The options for the **View additional system information menu** category are:

- | **Board Specifications**
- | **System Specifications**
- | **Used Resources**
- | **Available Resources**

The **Used Resources** and **Available Resources** options contain detailed information about resources such as IRQs, DMA channels, and I/O ports, which may be useful if you need to resolve a resource conflict.

Set Verification Mode Menu

The settings for the **Set verification mode menu** category are **Automatic** (the default) and **Manual**. When this category is set to **Automatic**, the RCU automatically checks for resource conflicts and tries to resolve them. Unless you are technically knowledgeable, leave this category set to **Automatic**.

Maintain SCI Files Menu

Each time you use the RCU to configure your system, the system configuration information is saved in a **.sci** file and in system memory. You should save the system configuration information to a backup file that can be used to restore the information if the **.sci** file is damaged or lost. The options for the **Maintain SCI files menu** category are **Open** (the default) and **Save As**.

The **Open** option creates a backup file that overwrites the existing configuration. The **Save As** option allows you to select the filename under which you want the **.sci** file saved.

Resolving Resource Conflicts

The RCU automatically resolves resource conflicts between PCI expansion cards. It is extremely unusual for the RCU to fail in resolving a resource conflict between two PCI expansion cards. If the RCU fails to resolve the conflict, see "Getting Help" in your *Installation and Troubleshooting Guide* for information on obtaining technical assistance.

[Back to Contents Page](#)

[Back to Contents Page](#)

Glossary: Dell™ PowerEdge™ 4400 Systems User's Guide

[A](#) • [B](#) • [C](#) • [D](#) • [E](#) • [F](#) • [G](#) • [H](#) • [I](#) • [J](#) • [K](#) • [L](#) • [M](#) • [N](#) • [O](#) • [P](#) • [Q](#) • [R](#) • [S](#) • [T](#) • [U](#) • [V](#) • [W](#) • [X](#) • [Y](#) • [Z](#)

The following list defines or identifies technical terms, abbreviations, and acronyms used in Dell user documents.

A

A

Abbreviation for ampere(s).

AC

Abbreviation for alternating current.

adapter card

An expansion card that plugs into an expansion-card connector on the computer's system board. An adapter card adds some specialized function to the computer by providing an interface between the expansion bus and a peripheral device. Examples of adapter cards include network cards, sound boards, and SCSI adapters.

ADC

Abbreviation for analog-to-digital converter.

ADI

Abbreviation for Autodesk Device Interface.

AI

Abbreviation for artificial intelligence.

ANSI

Acronym for American National Standards Institute.

application program

Software designed to help you perform a specific task, such as a spreadsheet or word processor. Application programs are distinct from operating system and utility software.

ASCII

Acronym for American Standard Code for Information Interchange. A text file containing only characters from the ASCII character set (usually created with a text editor, such as MS-DOS® Editor or Notepad in Microsoft® Windows® operating system) is called an ASCII file.

ASIC

Acronym for application-specific integrated circuit.

ASPI®

Acronym for Advanced SCSI programming interface.

autoexec.bat file

When you boot your computer, MS-DOS runs any commands contained in the text file, **autoexec.bat** (after running any commands in the **config.sys** file). An **autoexec.bat** file is not required to boot MS-DOS, but provides a convenient place to run commands that are essential for setting up a consistent computing environment—such as loading mouse or network software.

B

backup

A copy of a program or data file. As a precaution, you should back up your computer's hard-disk drive on a regular basis. Before making a change

to the configuration of your computer, you should back up important start-up files, such as **autoexec.bat** and **config.sys** for MS-DOS or **win.ini** and **system.ini** for Microsoft Windows.

base memory

Synonym for [conventional memory](#).

BASIC

Acronym for Beginner's All-Purpose Symbolic Instruction Code, a programming language. MS-DOS includes a version of BASIC.

batch file

An ASCII text file containing a list of commands that run in sequence. Batch files must have a filename extension of **.bat**.

baud rate

Data transmission speed. For example, modems are designed to transmit data at one or more specified baud rate(s) through the COM (serial) port of a computer.

BBS

Abbreviation for bulletin board service. A computer system that serves as a central location for accessing data or relaying messages by modem. For example, Dell's TechConnect BBS contains the latest version of software such as video drivers and the Dell Directory. If your system has a modem, you can access the BBS and download the most recent version of this software.

beep code

A diagnostic system message in the form of a series of beeps from your computer's speaker. See your *Installation and Troubleshooting Guide* for a complete discussion of system beep codes.

BIOS

Acronym for basic input/output system. Your computer's BIOS contains programs stored on a ROM chip. The BIOS controls the following functions:

- 1 Communications between the microprocessor and peripheral devices such as the keyboard and the video adapter
- 1 Miscellaneous functions, such as system messages

bit

The smallest unit of information interpreted by your computer.

block

A typical unit of disk storage consisting of a small number of sectors. This term usually refers to the fundamental unit of storage provided by an operating system. See also [block size](#) and [striping](#).

block size

The size of a block. See also [block](#) and [striping](#).

boot routine

When you start your computer, it clears all memory, initializes devices, and loads the operating system. Unless the operating system fails to respond, you can reboot (also called warm boot) your computer by pressing <Ctrl><Alt>; otherwise, you must perform a cold boot by pressing the reset button (if your computer has one) or by turning the computer off and then back on.

bootable diskette

You can start your computer from a diskette in drive A. To make a bootable diskette, insert a diskette in drive A, type `sys a:` at the command line prompt and then press <Enter>. Use this bootable diskette if your computer will not boot from the hard-disk drive.

bpi

Abbreviation for bits per inch.

bps

Abbreviation for bits per second.

BTU

Abbreviation for British thermal unit.

bus

A bus forms an information pathway between the components of a computer. Your computer contains an expansion bus that allows the microprocessor to communicate with controllers for all the various peripheral devices connected to the computer. Your computer also contains an address bus and a data bus for communications between the microprocessor and RAM.

byte

Eight contiguous bits of information; the basic data unit used by your computer.

BZT

Abbreviation for Bundesamt für Zulassungen in der Telecommunication.

C**C**

Abbreviation for Celsius.

cache

To facilitate quicker data retrieval, a storage area for keeping a copy of data or instructions. For example, your computer's BIOS may cache ROM code in faster RAM. Or a disk-cache utility may reserve RAM in which to store frequently accessed information from your computer's disk drives; when a program makes a request to a disk drive for data that is in the cache, the disk-cache utility can retrieve the data from RAM faster than from the disk drive.

card-edge connector

On the bottom of an expansion card, the metal-contact section that plugs into an expansion-card connector.

CCFT

Abbreviation for cold cathode fluorescent tube.

CD-ROM

Abbreviation for compact disc read-only memory. CD-ROM drives use optical technology to read data from compact discs. CDs are read-only storage devices; you cannot write new data to a CD with standard CD-ROM drives.

CGA

Abbreviation for color graphics adapter.

CIO

Abbreviation for comprehensive input/output.

cm

Abbreviation for centimeter(s).

CMOS

Acronym for complementary metal-oxide semiconductor. In computers, CMOS memory chips are often used for NVRAM storage.

COM

The MS-DOS device names for the first through fourth serial ports on your computer are COM1, COM2, COM3, and COM4. MS-DOS supports up to four serial ports. However, the default interrupt for COM1 and COM3 is IRQ4, and the default interrupt for COM2 and COM4 is IRQ3. Therefore, you must be careful when you configure software that runs a serial device so that you do not create an interrupt conflict.

CON

The MS-DOS device name for the console, which includes your computer's keyboard and text displayed on the screen.

config.sys file

When you boot your computer, MS-DOS runs any commands contained in the text file **config.sys** (before running any commands in the **autoexec.bat** file). A **config.sys** file is not required to boot MS-DOS, but provides a convenient place to run commands that are essential for setting up a consistent computing environment—such as loading device drivers with a **device=** statement.

controller

A chip or expansion card that controls the transfer of data between the microprocessor and a peripheral such as a diskette drive or the keyboard.

conventional memory

The first 640 KB of RAM. Unless they are specially designed, MS-DOS programs are limited to running in conventional memory. See also [EMM](#), [expanded memory](#), [extended memory](#), [HMA](#), [memory manager](#), [upper memory area](#), and [XMM](#).

coprocessor

A coprocessor relieves the computer's microprocessor of specific processing tasks. A math coprocessor, for example, handles numeric processing. A graphics coprocessor handles video rendering. The Intel® Pentium® microprocessor includes an integrated math coprocessor.

cpi

Abbreviation for characters per inch.

CPU

Abbreviation for central processing unit. See also [microprocessor](#).

cursor

In character-based MS-DOS programs, the cursor is usually a block or an underscore (possibly blinking) that represents the position at which the next character typed will appear. Windows programs can design their own cursors—common cursor symbols include the pointer arrow and the text-insertion I-beam.

D

DAC

Acronym for digital-to-analog converter.

DAT

Acronym for digital audio tape.

dB

Abbreviation for decibel(s).

dBA

Abbreviation for adjusted decibel(s).

DC

Abbreviation for direct current.

DDC

Acronym for display data channel. A VESA® standard mechanism that allows the system to communicate with the monitor and retrieve information about its capabilities.

device driver

A device driver allows the operating system or a program to interface correctly with a peripheral such as a printer or network card. Some device drivers—such as network drivers—must be loaded from the **config.sys** file (with a device= statement) or as memory-resident programs (usually, from the **autoexec.bat** file). Others—such as video drivers—must load when you start the program for which they were designed.

DHCP

Acronym for Dynamic Host Configuration Protocol.

diagnostics

See [diskette-based diagnostics](#).

DIMM

Acronym for dual in-line memory module.

DIN

Acronym for Deutsche Industrie Norm.

DIP

Acronym for dual in-line package. A circuit board, such as a system board or expansion card, may contain DIP switches for configuring the circuit board. DIP switches are always toggle switches, with an ON position and an OFF position.



directory

Directories help keep related files organized in a hierarchical, "inverted tree" structure. Each disk has a "root" directory; for example, a **C:\>** prompt normally indicates that you are at the root directory of hard-disk drive C. Additional directories that branch off of the root directory are called subdirectories. Subdirectories may contain additional directories branching off of them.

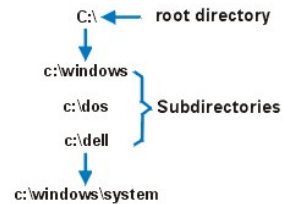

diskette-based diagnostics

A comprehensive set of diagnostic tests for your Dell computer. To use the diskette-based diagnostics, you must boot your computer from the *Dell Diagnostics Diskette*. Refer to your *Installation and Troubleshooting Guide* for a complete discussion about how to use the diskette-based diagnostics.

display adapter

See [video adapter](#).

DMA

Abbreviation for direct memory access. A DMA channel allows certain types of data transfer between RAM and a device to bypass the microprocessor.

DOC

Abbreviation for Department of Communications (in Canada).

dpi

Abbreviation for dots per inch.

DPMS

Abbreviation for Display Power Management Signaling. A standard developed by the Video Electronics Standards Association that defines the hardware signals sent by a video controller to activate power management states in a video display or monitor. A monitor is said to be DPMS-compliant when it is designed to enter a power management state after receiving the appropriate signal from a computer's video controller.

DRAC

Acronym for Dell OpenManage™ Remote Assistant Card.

DRAM

Abbreviation for dynamic random-access memory. A computer's RAM is usually made up entirely of DRAM chips. Because DRAM chips cannot store an electrical charge indefinitely, your computer continually refreshes each DRAM chip in the computer.

drive-type number

Your computer can recognize a number of specific hard-disk drives. Each is assigned a drive-type number that is stored in NVRAM. The hard-disk drive(s) specified in your computer's System Setup program must match the actual drive(s) installed in the computer. The System Setup program also allows you to specify physical parameters (cylinders, heads, write precomp, landing zone, and capacity) for drives not included in the table of drive types stored in NVRAM.

DS/DD

Abbreviation for double-sided/double-density.

DS/HD

Abbreviation for double-sided/high-density.

DTE

Abbreviation for data terminal equipment. Any device (such as a computer system) that can send data in digital form by means of a cable or communications line. The DTE is connected to the cable or communications line through a data communications equipment (DCE) device such as a modem.

E

ECC

Abbreviation for error checking and correction.

ECP

Abbreviation for Extended Capabilities Port.

EDO

Abbreviation for extended-data out. A type of RAM chip that holds data on the chip's output data lines for a longer period of time than fast-page mode RAM chips. The EDO RAM chips are also faster than fast-page mode RAM chips.

EEPROM

Acronym for electrically erasable programmable read-only memory.

EGA

Abbreviation for enhanced graphics adapter.

EISA

Acronym for Extended Industry-Standard Architecture, a 32-bit expansion-bus design. The expansion-card connectors in an EISA computer are also compatible with 8- or 16-bit ISA expansion cards.

To avoid a configuration conflict when installing an EISA expansion card, you must use the EISA Configuration Utility. This utility allows you to specify which expansion slot contains the card and obtains information about the card's required system resources from a corresponding EISA configuration file.

EMC

Abbreviation for Electromagnetic Compatibility.

EMI

Abbreviation for electromagnetic interference.

EMM

Abbreviation for expanded memory manager. A software utility that uses extended memory to emulate expanded memory on computers with an Intel386™ or higher microprocessor. See also [conventional memory](#), [expanded memory](#), [extended memory](#), [memory manager](#), and [XMM](#).

EMP

Abbreviation for emergency management port.

EMS

Abbreviation for Expanded Memory Specification. See also [expanded memory](#), [memory manager](#), and [XMS](#).

EPROM

Acronym for erasable programmable read-only memory.

ESD

Abbreviation for electrostatic discharge. See "[Safety Instructions](#)" for a complete discussion of ESD.

ESDI

Acronym for enhanced small-device interface.

expanded memory

A technique for accessing RAM above 1 MB. To enable expanded memory on your computer, you must use an EMM. You should configure your system to support expanded memory only if you run application programs that can use (or require) expanded memory. See also [conventional memory](#), [EMM](#), [extended memory](#), and [memory manager](#).

expansion bus

Your computer contains an expansion bus that allows the microprocessor to communicate with controllers for peripheral devices, such as a network card or an internal modem.

expansion-card connector

A connector on the computer's system board for plugging in an expansion card.

extended memory

RAM above 1 MB. Most software that can use it, such as Windows, requires that extended memory be under the control of an XMM. See also [conventional memory](#), [expanded memory](#), [memory manager](#), and [XMM](#).

external cache memory

A RAM cache using SRAM chips. Because SRAM chips operate at several times the speed of DRAM chips, the microprocessor can retrieve data and instructions faster from external cache memory than from RAM.

F

F

Abbreviation for Fahrenheit.

FAT

Acronym for file allocation table. The file system structure used by MS-DOS to organize and keep track of file storage. The Microsoft Windows NT® operating system can optionally use a FAT file system structure.

FCC

Abbreviation for Federal Communications Commission.

flash memory

A type of EEPROM chip that can be reprogrammed from a utility on diskette while still installed in a computer; most EEPROM chips can only be rewritten with special programming equipment.

format

To prepare a hard-disk drive or diskette for storing files. An unconditional format deletes all data stored on the disk. The format command in MS-DOS 5.0 or higher includes an option that allows you to unformat a disk if you have not yet used the disk for file storage.

ft

Abbreviation for foot/feet.

FTP

Abbreviation for file transfer protocol.

G

g

Abbreviation for gram(s).

G

Abbreviation for gravities.

GB

Abbreviation for gigabyte(s). A gigabyte equals 1024 megabytes or 1,073,741,824 bytes.

graphics coprocessor

See [coprocessor](#).

graphics mode

See [video mode](#).

guarding

A type of data redundancy that uses a set of physical drives to store data and a single, additional drive to store parity data. Data is protected from the loss of a single drive. Guarding is sometimes preferred over mirroring because it is more cost-effective in systems with a very high storage capacity. However, guarded configurations are significantly slower for applications that frequently write to the array, because each attempt to write to the array requires multiple read and write commands to maintain the parity information. If this is a problem, mirroring or duplexing is a better choice. See also [mirroring](#), [RAID 4](#), and [RAID 5](#).

GUI

Acronym for graphical user interface.

H**h**

Abbreviation for hexadecimal. A base-16 numbering system, often used in programming to identify addresses in the computer's RAM and I/O memory addresses for devices. The sequence of decimal numbers from 0 through 16, for example, is expressed in hexadecimal notation as: 0, 1, 2, 3, 4, 5, 6, 7, 8, 9, A, B, C, D, E, F, 10. In text, hexadecimal numbers are often followed by h or preceded by 0x. MS-DOS conventional memory—the first 640 KB of memory addresses—is from 00000h to 9FFFFh; the MS-DOS upper memory area—memory addresses between 640 KB and 1 MB—is from A0000h to FFFFFh.

heat sink

A metal plate with metal pegs or ribs that help dissipate heat. Some microprocessors include a heat sink.

HMA

Abbreviation for high memory area. The first 64 KB of extended memory above 1 MB. A memory manager that conforms to the XMS can make the HMA a direct extension of conventional memory. See also [conventional memory](#), [memory manager](#), [upper memory area](#), and [XMM](#).

host adapter

A host adapter implements communication between the computer's bus and the controller for a peripheral. (Hard-disk drive controller subsystems include integrated host adapter circuitry.) To add a SCSI expansion bus to your system, you must install the appropriate host adapter.

HPFS

Abbreviation for the High Performance File System option in the Windows NT operating system.

Hz

Abbreviation for hertz.

I**I₂O**

Abbreviation for intelligent input/output.

IC

Abbreviation for integrated circuit.

ICMB

Abbreviation for inter-chassis management bus.

I/O

Abbreviation for input/output. The keyboard and a printer, for example, are I/O devices. In general, I/O activity can be differentiated from computational activity. For example, when a program sends a document to the printer, it is engaging in I/O activity; when the program sorts a list of terms, it is engaging in computational activity.

ID

Abbreviation for identification.

interlacing

A technique for increasing video resolution by only updating alternate horizontal lines on the screen. Because interlacing can result in noticeable screen flicker, most users prefer noninterlaced video adapter resolutions.

internal microprocessor cache

An instruction and data cache built into the microprocessor. The Pentium microprocessor, for example, includes a 16-KB internal cache, which is set up as an 8-KB read-only instruction cache and an 8-KB read/write data cache.

IP

Acronym for Internet Protocol.

IPX

Abbreviation for Internetwork Packet eXchange.

IRQ

Abbreviation for interrupt request. A signal that data is about to be sent to or received by a peripheral travels by an IRQ line to the microprocessor. Each peripheral connection must be assigned an IRQ number. For example, the first serial port in your computer (COM1) is assigned to IRQ4 by default. Two devices can share the same IRQ assignment, but you cannot operate both devices simultaneously.

RTOS

Abbreviation for I₂O real-time operating system.

ISA

Acronym for Industry-Standard Architecture. A 16-bit expansion bus design. The expansion-card connectors in an ISA computer are also compatible with 8-bit ISA expansion cards.

ITE

Abbreviation for information technology equipment.

J

JEIDA

Acronym for Japanese Electronic Industry Development Association.

K

K

Abbreviation for kilo-, indicating 1000.

KB

Abbreviation for kilobyte(s), 1024 bytes.

KB/sec

Abbreviation for kilobyte(s) per second.

Kbit(s)

Abbreviation for kilobit(s), 1024 bits.

Kbps

Abbreviation for kilobit(s) per second.

key combination

A command requiring that you press multiple keys at the same time. For example, you can reboot your computer by pressing the <Ctrl><Alt> key combination.

kg

Abbreviation for kilogram(s), 1000 grams.

kHz

Abbreviation for kilohertz, 1000 hertz.

L**LAN**

Acronym for local area network. A LAN system is usually confined to the same building or a few nearby buildings, with all equipment linked by wiring dedicated specifically to the LAN.

lb

Abbreviation for pound(s).

LCD

Abbreviation for liquid crystal display. A low-power display often used for notebook computers. An LCD consists of a liquid crystal solution between two sheets of polarizing material. An electric current causes each crystal to act like a shutter that can open to allow light past or close to block the light.

LED

Abbreviation for light-emitting diode. An electronic device that lights up when a current is passed through it.

LIF

Acronym for low insertion force. Some computers use LIF sockets and connectors to allow devices such as the microprocessor chip to be installed or removed with minimal stress to the device.

LN

Abbreviation for load number.

local bus

On a computer with local-bus expansion capability, certain peripheral devices (such as the video adapter circuitry) can be designed to run much faster than they would with a traditional expansion bus. Some local-bus designs allow peripherals to run at the same speed and with the same-width data path as the computer's microprocessor.

LPTn

The MS-DOS device names for the first through third parallel printer ports on your computer are LPT1, LPT2, and LPT3.

LUN

Acronym for logical unit number.

M**m**

Abbreviation for meter(s).

mA

Abbreviation for milliampere(s).

mAh

Abbreviation for milliampere-hour(s).

math coprocessor

See [coprocessor](#).

MB

Abbreviation for megabyte(s). The term megabyte means 1,048,576 bytes; however, when referring to hard-disk drive storage, the term is often rounded to mean 1,000,000 bytes.

MBR

Abbreviation for master boot record.

MDA

Abbreviation for monochrome display adapter.

memory

A computer can contain several different forms of memory, such as RAM, ROM, and video memory. Frequently, the word memory is used as a synonym for RAM; for example, an unqualified statement such as "a computer with 8 MB of memory" refers to a computer with 8 MB of RAM.

memory address

A specific location, usually expressed as a hexadecimal number, in the computer's RAM.

memory manager

A utility that controls the implementation of memory in addition to conventional memory, such as extended or expanded memory. See also [conventional memory](#), [EMM](#), [expanded memory](#), [extended memory](#), [HMA](#), [upper memory area](#), and [XMM](#).

MGA

Abbreviation for monochrome graphics adapter.

MHz

Abbreviation for megahertz.

microprocessor

Because it is the primary computational chip inside the computer, it is customary to refer to the microprocessor as "the computer's brain." The microprocessor contains an arithmetic processing unit and a control unit. Software written for one microprocessor must usually be revised to run on another microprocessor. CPU is a synonym for microprocessor.

min

Abbreviation for minute(s).

mirroring

A type of data redundancy that uses a set of physical drives to store data and one or more sets of additional drives to store duplicate copies of the data. Mirroring is the preferred data redundancy technique in lower-capacity systems and in systems where performance is extremely important. See also [guarding](#), [RAID 1](#), and [RAID 10](#).

mm

Abbreviation for millimeter(s).

mouse

A pointing device that controls the movement of the cursor on a screen. Mouse-aware software allows you to activate commands by clicking a mouse button while pointing at objects displayed on the screen.

MPS

Abbreviation for multiprocessing specification.

ms

Abbreviation for millisecond(s).

MS-DOS

Abbreviation for Microsoft Disk Operating System.

MTBF

Abbreviation for mean time between failures.

multifrequency monitor

A monitor that supports several video standards. A multifrequency monitor can adjust to the frequency range of the signal from a variety of video adapters.

mV

Abbreviation for millivolt(s).

N**NIC**

Acronym for network interface controller.

NiCad

Acronym for nickel cadmium.

NiMH

Abbreviation for nickel-metal hydride.

NLM

Acronym for NetWare® Loadable Module.

NMI

Abbreviation for nonmaskable interrupt. A device sends an NMI to signal the microprocessor about hardware errors such as parity errors.

noninterlaced

A technique for decreasing screen flicker by sequentially refreshing each horizontal line on the screen.

ns

Abbreviation for nanosecond(s), one billionth of a second.

NTFS

Abbreviation for the NT File System option in the Windows NT operating system.

NVRAM

Abbreviation for nonvolatile random-access memory. Memory that does not lose its contents when you turn off your computer. NVRAM is used for maintaining the date, time, and system setup options.

O**OS/2®**

Abbreviation for Operating System/2.

OTP

Abbreviation for one-time programmable.

P

parallel port

An I/O port used most often to connect a parallel printer to your computer. You can usually identify a parallel port on your computer by its 25-hole connector.

parameter

A value or option that you specify to a program. A parameter is sometimes called a switch or an argument.

partition

You can divide a hard-disk drive into multiple physical sections called partitions with the **fdisk** command. Each partition can contain multiple logical drives. For example, you could partition a 2-GB hard-disk drive into two physically separate partitions with three logical drive assignments, as shown in the following table.

Partitioning the Hard-Disk Drive

Physical Partitions and Sizes
Partition 1 - 1.2 GB / Partition 2 - 800 MB
Logical Drive Assignments and Sizes
Drive C - 1.2 GB / Drive D - 500 MB / Drive E - 300 MB

After partitioning the hard-disk drive, you must format each logical drive with the format command.

PC Card

Slightly larger than a credit card, a PC Card is a removable I/O card—such as a modem, LAN, SRAM, or flash memory card—that adheres to the PCMCIA standards. See also [PCMCIA](#).

PCI

Abbreviation for Peripheral Component Interconnect. A standard for local-bus implementation developed by Intel Corporation.

PCMCIA

Abbreviation for Personal Computer Memory Card International Association. See also [PC Card](#).

PDC

Acronym for primary domain controller.

PERC

Acronym for PowerEdge Expandable RAID controller.

peripheral device

An internal or external device—such as a printer, a disk drive, or a keyboard—connected to a computer.

PGA

Abbreviation for pin grid array, a type of microprocessor socket that allows you to remove the microprocessor chip.

pixel

Arranged in rows and columns, a pixel is a single point on a video display. Video resolution—640 x 480, for example—is expressed as the number of pixels across by the number of pixels up and down.

POST

Acronym for power-on self-test. Before the operating system loads when you turn on your computer, the POST tests various system components such as RAM, the disk drives, and the keyboard.

ppm

Abbreviation for pages per minute.

PQFP

Abbreviation for plastic quad flat pack, a type of microprocessor socket in which the microprocessor chip is permanently mounted.

program diskette set

The set of diskettes from which you can perform a complete installation of an application program. When you reconfigure a program, you often need its program diskette set.

protected mode

An operating mode supported by 80286 or higher microprocessors, protected mode allows operating systems to implement:

- 1 A memory address space of 16 MB (80286 microprocessor) to 4 GB (Intel386 or higher microprocessor)
- 1 Multitasking
- 1 Virtual memory, a method for increasing addressable memory by using the hard-disk drive

The Windows NT 32-bit operating system runs in protected mode. MS-DOS cannot run in protected mode; however, some programs that you can start from MS-DOS—such as Windows—are able to put the computer into protected mode.

PS/2

Abbreviation for Personal System/2.

PSPB

Abbreviation for power-supply paralleling board.

PVC

Abbreviation for polyvinyl chloride.

Q

QIC

Abbreviation for quarter-inch cartridge.

R

RAID

Acronym for redundant arrays of independent disks. This phrase was introduced by David Patterson, Garth Gibson, and Randy Katz at the University of California at Berkeley in 1987. The goal of RAID is to use multiple small, inexpensive disk drives to provide high storage capacity and performance while maintaining or improving the reliability of the disk subsystem.

Patterson, Gibson, and Katz described five different methods, which are known as RAID levels 1 through 5. Each level uses one or more extra drives to provide a means of recovering data lost when a disk fails, so that the effective failure rate of the whole disk subsystem becomes very low.

RAID 0

RAID 0 is commonly called striping. This was not originally defined as a RAID level but has since come into popular use. In this array configuration, data is written sequentially across the available disks and no redundancy is provided. RAID 0 configurations provide very high performance but relatively low reliability. RAID 0 is the best choice when controller cards are duplexed. See also [striping](#).

RAID 1

RAID 1 is commonly called mirroring. RAID 1 also uses striping, so RAID 1 may be regarded as the mirroring of RAID 0 configurations. RAID 1 is the best choice in high-availability applications that require high performance or relatively low data capacity. See also [mirroring](#), [RAID 10](#), [striping](#).

RAID 4

RAID 4 is commonly called guarding. It uses data striping, like RAID 0, but adds a single, dedicated parity drive. The parity data stored on this drive can be used to recover data lost from a single failed drive. RAID 4 configurations write data slowly because parity data has to be generated and written to the parity drive, and the generation of the parity data frequently requires reading data from multiple physical drives. See also [guarding](#) and [striping](#).

RAID 5

RAID 5, like RAID 4, is commonly called guarding. RAID 5 is identical to RAID 4, except that the parity data is distributed evenly across all physical drives instead of a parity drive. In configurations using a large number of physical drives in which a large number of simultaneous small write operations are being performed, RAID 5 offers potentially higher performance than RAID 4. RAID 4 and RAID 5 configurations are appropriate in high-availability applications where performance is less critical or where high data capacity is required. See also [guarding](#).

RAID 10

RAID 10 is a mirroring technique in which data is duplicated across two identical RAID 0 arrays or hard-disk drives. All data on a physical drive in one array is duplicated, or mirrored, on a drive in the second array. Mirroring offers complete redundancy of data for greater data security. See also [mirroring](#), [RAID 1](#), and [striping](#).

RAM

Acronym for random-access memory. The computer's primary temporary storage area for program instructions and data. Each location in RAM is identified by a number called a memory address. Any information stored in RAM is lost when you turn off your computer.

RAMDAC

Acronym for random-access memory digital-to-analog converter.

RCA

Acronym for Resource Configuration Add-in.

RCU

Acronym for Resource Configuration Utility.

read-only file

A read-only file is one that you are prohibited from editing or deleting. A file can have read-only status if:

- 1 Its read-only attribute is enabled.
- 1 It resides on a physically write-protected diskette.
- 1 It is located on a network in a directory to which the system administrator has assigned read-only rights to you.

real mode

An operating mode supported by 80286 or higher microprocessors, real mode imitates the architecture of an 8086 microprocessor. Designed to run in real mode, MS-DOS (unassisted by additional software techniques) can address only 640 KB of conventional memory.

refresh rate

The frequency, measured in Hz, at which the screen's horizontal lines are recharged. A monitor's refresh rate is also referred to as its vertical frequency.

REN

Abbreviation for ringer equivalence number.

RFI

Abbreviation for radio frequency interference.

RGB

Abbreviation for red/green/blue.

ROM

Acronym for read-only memory. Your computer contains some programs essential to its operation in ROM code. Unlike RAM, a ROM chip retains its contents even after you turn off your computer. Examples of code in ROM include the program that initiates your computer's boot routine and the POST.

rpm

Abbreviation for revolutions per minute.

RTC

Abbreviation for real-time clock. Battery-powered clock circuitry inside the computer that keeps the date and time after you turn off the computer.

S

SCSI

Acronym for small computer system interface. An I/O bus interface with faster data transmission rates than standard ports. You can connect up to seven devices to one SCSI interface.

SDMS

Abbreviation for SCSI device management system.

SDRAM

Abbreviation for synchronous dynamic random-access memory.

SDS

Abbreviation for scalable disk system.

SEC

Abbreviation for single-edge contact.

sec

Abbreviation for second(s).

sector

The fundamental unit of data access for a hard-disk drive. For PC-compatible systems, a sector is usually 512 bytes. See also [block](#) and [block size](#).

serial port

An I/O port used most often to connect a modem or a mouse to your computer. You can usually identify a serial port on your computer by its 9-pin connector.

SIMD

Acronym for single instruction, multiple data.

shadowing

A computer's system and video BIOS code is usually stored on ROM chips. Shadowing refers to the performance-enhancement technique that copies BIOS code to faster RAM chips in the upper memory area (above 640 KB) during the boot routine.

SMART

Acronym for Self-Monitoring Analysis and Reporting Technology. A technology that allows hard-disk drives to report errors and failures to the system BIOS, which then displays an error message on the screen. To take advantage of this technology, you must have a SMART-compliant hard-disk drive and the proper support in the system BIOS.

SMB

Abbreviation for system management bus.

SMP

Abbreviation for symmetric multiprocessing.

SNMP

Abbreviation for Simple Network Management Protocol.

striping

In composite drivers with two or more physical drives, the drive array subsystem uses a method of data storage called striping. With this method, data is divided into a series of pieces called blocks and each data block is stored on a different physical drive. When each drive contains a block of data, the process starts over with the first physical drive. When the size of the data block is carefully selected, the chance that the information needed can be read from or written to multiple physical drives at once is increased, greatly increasing the performance of the composite drive. See also [block](#), [block size](#), and [RAID](#).

SRAM

Abbreviation for static random-access memory. Because SRAM chips do not require continual refreshing, they are substantially faster than DRAM chips. SRAM is used mostly for external cache memory.

SVGA

Abbreviation for super video graphics array. See also [VGA](#).

switch

See [parameter](#).

sync negotiation

Sync negotiation is a SCSI feature that allows the host adapter and its attached SCSI devices to transfer data in synchronous mode. Synchronous data transfer is faster than asynchronous data transfer.

syntax

The rules that dictate how you must type a command or instruction so that the computer will understand it.

system board

As the main circuit board, the system board usually contains most of your computer's integral components, such as the following:

- 1 Microprocessor
- 1 RAM
- 1 Expansion-card connectors
- 1 Controllers for standard peripheral devices such as the keyboard
- 1 Various ROM chips

Frequently used synonyms for system board are motherboard and logic board.

system diskette

System diskette is a synonym for [bootable diskette](#).

system memory

System memory is a synonym for [RAM](#).

System Setup program

System Setup program options allow you to configure your computer's hardware. Some options in the System Setup program require that you reboot the computer to effect a hardware-configuration change. Because the System Setup program is stored in NVRAM, any options that you set remain in effect until you change them again.

system.ini file

When you start Windows, it consults the **system.ini** file to determine a variety of options for the Windows operating environment. Among other things, the **system.ini** file records which video, mouse, and keyboard drivers are installed for Windows.

Revising the **Control Panel** settings or running the Windows Setup program may change options in the **system.ini** file. On other occasions, you may need to change or add options to the **system.ini** file manually with a text editor, such as Notepad.

T

TCP/IP

Abbreviation for Transmission Control Protocol/Internet Protocol.

terminator

Some devices, especially disk drives, contain a terminator to absorb and dissipate excess current. When more than one such device is connected in a series, you may need to remove the terminator—or change a jumper setting to disable it—unless it is the last device in the series. However, some devices have terminators that should never be removed or disabled.

text editor

An application program for editing text files consisting exclusively of ASCII characters. MS-DOS Editor and Notepad (in Windows) are text editors, for example. Most word processors use proprietary file formats containing binary characters, although some can read and write text files.

text mode

See [video mode](#).

TFT

Abbreviation for thin film transistor. A flat-panel display for notebook computers where each pixel is controlled by one to four transistors.

tpi

Abbreviation for tracks per inch.

TSR

Abbreviation for terminate-and-stay-resident. A TSR program runs "in the background." Most TSR programs implement a predefined key combination (sometimes referred to as a "hot key") that allows you to activate the TSR program's interface while running another MS-DOS program. When you finish using the TSR program, you can return to the other application program and leave the TSR program resident in memory for later use.

Because MS-DOS is not designed to support multiple programs running simultaneously, TSR programs can sometimes cause memory conflicts. When troubleshooting, rule out the possibility of such a conflict by rebooting your computer without starting any TSR programs.

TV

Abbreviation for television.

U

UL

Abbreviation for Underwriters Laboratories.

UMB

Abbreviation for upper memory blocks. See also [conventional memory](#), [HMA](#), [memory manager](#), and [upper memory area](#).

upper memory area

The 384 KB of RAM located between 640 KB and 1 MB. If the computer has an Intel386 or higher microprocessor, a software utility called a memory manager can create UMBs in the upper memory area, in which you can load device drivers and memory-resident programs. See also [conventional memory](#), [HMA](#), and [memory manager](#).

UPS

Abbreviation for uninterruptible power supply. A battery-powered unit that automatically supplies power to your computer in the event of an electrical failure.

USB

Abbreviation for Universal Serial Bus.

USOC

Abbreviation for Universal Service Ordering Code.

utility

A program used to manage system resources—memory, disk drives, or printers, for example. The **diskcopy** command for duplicating diskettes and the **himem.sys** device driver for managing extended memory are utilities included in MS-DOS.

V

V

Abbreviation for volt(s).

VAC

Abbreviation for volt(s) alternating current.

VCCI

Abbreviation for Voluntary Control Council for Interference.

VDC

Abbreviation for volt(s) direct current.

VDE

Abbreviation for Verband Deutscher Elektrotechniker.

VESA

Acronym for Video Electronics Standards Association.

VGA

Abbreviation for video graphics array. VGA and SVGA are video standards for video adapters with greater resolution and color display capabilities than EGA and CGA, the previous standards.

To display a program at a specific resolution, you must install the appropriate video drivers and your monitor must support the resolution. Similarly, the number of colors that a program can display depends on the capabilities of the monitor, the video driver, and the amount of memory installed for the video adapter.

VGA feature connector

On some systems with an integrated VGA video adapter, a VGA feature connector allows you to add an enhancement adapter, such as a video accelerator, to your computer. A VGA feature connector can also be called a VGA pass-through connector.

video adapter

The logical circuitry that provides—in combination with the monitor or display—your computer's video capabilities. A video adapter may support more or fewer features than a specific monitor offers. Typically, a video adapter comes with video drivers for displaying popular application programs and operating environments in a variety of video modes.

On most current Dell computers, a video adapter is integrated into the system board. Also available are many video adapter cards that plug into an expansion-card connector.

Video adapters can include memory separate from RAM on the system board. The amount of video memory, along with the adapter's video drivers, may affect the number of colors that can be simultaneously displayed. Video adapters can also include their own coprocessor chip for faster graphics rendering.

video driver

Graphics-mode application programs and operating environments, such as Windows, often require video drivers to display at a chosen resolution with the desired number of colors. A program may include some "generic" video drivers. Any additional video drivers may need to match the video adapter; you can find these drivers on a separate diskette with your computer or video adapter.

video memory

Most VGA and SVGA video adapters include VRAM or DRAM memory chips in addition to your computer's RAM. The amount of video memory installed primarily influences the number of colors that a program can display (with the appropriate video drivers and monitor capability).

video mode

Video adapters normally support multiple text and graphics display modes. Character-based software (such as MS-DOS) displays in text modes that can be defined as x columns by y rows of characters. Graphics-based software (such as Windows) displays in graphics modes that can be defined as x horizontal by y vertical pixels by z colors.

video resolution

Video resolution—640 x 480, for example—is expressed as the number of pixels across by the number of pixels up and down. To display a program at a specific graphics resolution, you must install the appropriate video drivers and your monitor must support the resolution.

virtual 8086 mode

An operating mode supported by Intel386 or higher microprocessors, virtual 8086 mode allows operating environments—such as Windows—to run multiple programs in separate 1-MB sections of memory. Each 1-MB section is called a virtual machine.

virtual memory

A method for increasing addressable RAM by using the hard-disk drive. (MS-DOS does not support true virtual memory, which must be implemented at the operating-system level.) For example, in a computer with 8 MB of RAM and 16 MB of virtual memory set up on the hard-disk drive, the operating system would manage the system as though it had 24 MB of physical RAM.

virus

A self-starting program designed to inconvenience you. Virus programs have been known to corrupt the files stored on a hard-disk drive or to replicate themselves until a system or network runs out of memory.

The most common way that virus programs move from one system to another is via "infected" diskettes, from which they copy themselves to the hard-disk drive. To guard against virus programs, you should do the following:

- 1 Periodically run a virus-checking utility on your computer's hard-disk drive.
- 1 Always run a virus-checking utility on any diskettes (including commercially sold software) before using them.

VL-Bus™

An abbreviation for VESA local bus. A standard for local bus implementation developed by the Video Electronics Standards Association.

VLSI

Abbreviation for very-large-scale integration.

Vpp

Abbreviation for peak-point voltage.

VRAM

Abbreviation for video random-access memory. Some video adapters use VRAM chips (or a combination of VRAM and DRAM) to improve video performance. VRAM is dual-ported, allowing the video adapter to update the screen and receive new image data at the same time.

W

W

Abbreviation for watt(s).

win.ini file

When you start Windows, it consults the **win.ini** file to determine a variety of options for the Windows operating environment. Among other things, the **win.ini** file records what printer(s) and fonts are installed for Windows. The **win.ini** file also usually includes sections that contain optional settings for Windows application programs that are installed on the hard-disk drive.

Revising the **Control Panel** settings or running the Windows Setup program may change options in the **win.ini** file. On other occasions, you may need to change or add options to the **win.ini** file manually with a text editor such as Notepad.

write-protected

Read-only files are said to be write-protected. You can write-protect a 3.5-inch diskette by sliding its write-protect tab to the open position; you can write-protect a 5.25-inch diskette by placing an adhesive label over its write-protect notch.

WWW

Abbreviation for World Wide Web.

X

XMM

Abbreviation for extended memory manager, a utility that allows application programs and operating environments to use extended memory in accordance with the XMS. See also [conventional memory](#), [EMM](#), [expanded memory](#), [extended memory](#), and [memory manager](#).

XMS

Abbreviation for eXtended Memory Specification. See also EMS, [extended memory](#), and [memory manager](#).

Z

ZIF

Acronym for zero insertion force. Some computers use ZIF sockets and connectors to allow devices such as the microprocessor chip to be installed or removed with no stress applied to the device.

[Back to Contents Page](#)

Introduction: Dell™ PowerEdge™ 4400 Systems User's Guide

[Overview](#)

[System Features](#)

[Supported Operating Systems](#)

[Front Panel](#)

[Connecting External Devices](#)

[Preventing Unauthorized Access Inside the Computer](#)

[Getting Help](#)

Overview

The Dell PowerEdge 4400, which has an Intel® Pentium® III Xeon™ microprocessor, is a feature-rich, enterprise class server that offers the highest performance, availability, scalability, manageability, and investment protection features. The PowerEdge 4400 includes a hot-pluggable 64-bit/66-megahertz (MHz) Peripheral Component Interconnect (PCI) bus, an integrated Ultra 160/m small computer system interface (SCSI), and an optional integrated redundant arrays of independent disks (RAID) with battery back-up cache. The PowerEdge 4400 provides a robust, reliable, rack-optimized platform on which large corporate customers can deploy their mission-critical applications.

This section describes the major hardware and software features of the computer, provides information about the indicators and controls on the computer's front panel, and discusses connecting external devices to the computer.

System Features

PowerEdge 4400 systems offer the following major features:

- 1 One or two Pentium III Xeon microprocessors.

The **Processor Core** option on **Page 1** of the System Setup program lists your system's processor speed. For more information, see "[Using the System Setup Program](#)."

The Pentium III Xeon microprocessor includes MMX™ technology designed to handle complex multimedia and communications software. This microprocessor incorporates new instructions and data types as well as a technique called single instruction, multiple data (SIMD) that allows the microprocessor to process multiple data elements in parallel, thereby improving overall system performance.

A secondary level 2 (L2) cache of static random-access memory (SRAM) is included within the single-edge contact (SEC) cartridge that contains the microprocessor. Math coprocessor functions are provided by the microprocessor. A separate and external math coprocessor chip is not used or required.

The size of the L2 cache is dependent on the processor installed in the system. The first screen of the system setup program lists the system's cache size. For more information, see "[Using the System Setup Program](#)."

- 1 Front side bus (FSB) with an external bus speed of 133 MHz.
- 1 Support for symmetric multiprocessing is available by installing a second Pentium III Xeon microprocessor. Symmetric multiprocessing greatly improves overall system performance by dividing microprocessor operations between the two independent microprocessors. To take advantage of this feature, you must use an operating system that supports multiprocessing, such as Microsoft® Windows NT® Server 4.0 or Novell® NetWare® 4.2 (and later versions).

 **NOTE:** If you decide to upgrade your system by installing a second microprocessor, you must order a microprocessor upgrade kit from Dell. Not all versions of the Pentium III Xeon microprocessor work properly as a second microprocessor. The upgrade kit contains the correct version of the microprocessor for use as a second microprocessor as well as instructions for performing the upgrade.

- 1 A minimum of 128 megabytes (MB) of system memory, upgradable to a maximum of 4 gigabytes (GB) by installing combinations of 64-, 128-, 256-, or 512 MB registered synchronous dynamic RAM (SDRAM) dual in-line memory modules (DIMMs) in the eight DIMM sockets on the system board. These DIMMs must be installed in equal pairs.
- 1 A basic input/output system (BIOS) that resides in flash memory on the PCI bus that can be upgraded if required.
- 1 Eight 1-inch or six 1.6-inch, hot-pluggable, SCSI hard-disk drives.
- 1 Two additional 1-inch drives can be installed in the optional removable media bay via a 1 x 2 SCSI backplane board. If this backplane is configured as a split backplane using two SCSI cable connections, these two drives are hot-pluggable.
- 1 A power-supply distribution board to accommodate up to three independent power supplies. Two power supplies are standard; a third can be added to make the system redundant.
- 1 Redundant, hot-pluggable fans that run independently.

- 1 A single, 1.44-MB 3.5-inch diskette drive.
- 1 A 17/40x SCSI CD-ROM drive.

The system board includes the following integrated features:

- 1 Seven PCI slots located on the system board. PCI slots 1 through 4 are hot-pluggable. PCI slots 1 and 2 are 64-bit, 66-MHz PCI slots; PCI slots 3 and 4 are 64-bit, 33-MHz PCI slots; PCI slots 5 and 6 are 64-bit, 33-MHz slots. Slot 7 provides a 32-bit, 33-MHz PCI slot for use with the optional Dell OpenManage™ Remote Assistant Card (DRAC) or other PCI accessories.
- 1 An integrated Intel PRO/100+ network interface controller (NIC), which provides an Ethernet interface and failover and load balancing with single and dual ports.
- 1 An integrated Adaptec AIC-7899 dual-channel Ultra 160/m SCSI host adapter that supports up to ten SCSI hard-disk drives (eight 1-inch hard disk drives via a SCSI backplane board and two 1-inch hard-disk drives via an external SCSI hard-disk drive media bay). The SCSI backplane automatically configures SCSI ID numbers and SCSI termination on individual hard-disk drives, greatly simplifying drive installation.
- 1 An optional integrated PowerEdge Expandable RAID Controller (PERC) 3/Di that supports RAID levels 0, 1, 5, and 10. The Ultra 160/m SCSI host adapter can become RAID capable with the addition of the PERC 3/Di.
- 1 An integrated Adaptec AIC-7880 Ultra/Wide SCSI secondary host adapter (implemented as Ultra/Narrow) that supports up to three externally accessible SCSI devices in the external hard-disk drive bays (for example, CD-ROM drive, tape drive unit).
- 1 An integrated video graphics array (VGA)-compatible video subsystem with an ATI RAGE IIC video controller. This video subsystem contains 4 MB of synchronous dynamic RAM (SDRAM) video memory (nonupgradable). Maximum resolutions are 1600 x 1200 x 65K colors (noninterlaced). The maximum true-color resolution is 1152 x 864; 16.7 million colors are available for true-color graphics.
- 1 An integrated National Semiconductor PC97317 super input/output (I/O) controller that controls the bidirectional parallel port, two serial ports, keyboard, mouse, and the diskette drive in the externally accessible front bay.

The parallel port can be set to operate in the following modes via the **Parallel Mode** option in the System Setup program: output-only (AT-compatible), bidirectional (Personal System/2 [PS/2]-compatible).

- 1 Integrated server management circuitry that monitors operation of the system fans as well as critical system voltages and temperatures. The integrated server management circuitry works in conjunction with the optional HP OpenView Network Node Manager Special Edition (NNM SE) and the Dell OpenManage Hardware Instrumentation Package (HIP) software package.
- 1 System board support for the Dell OpenManage Remote Assistant when the optional DRAC 2 is installed, which provides additional local and remote server management.
- 1 A PS/2-style keyboard port, dual Universal Serial Bus (USB) ports, and a PS/2-compatible mouse port.

Standard PowerEdge 4400 systems include a 3.5-inch diskette drive and a SCSI CD-ROM drive installed in the externally accessible bays and a SCSI hard-disk drive installed in slot 0.

The following software is included in your PowerEdge system:

- 1 Video drivers for displaying many popular application programs in high-resolution modes. For more information on these drivers, see "[Using the Dell OpenManage Server Assistant CD](#)."
- 1 SCSI device drivers that allow the operating system to communicate with devices attached to the integrated SCSI subsystem. For more information on these drivers, see "[Installing and Configuring SCSI Drivers](#)."
- 1 The [System Setup program](#) for quickly viewing and changing the system configuration information for your computer.
- 1 The [Resource Configuration Utility](#), which allows you to configure installed expansion cards through software rather than on the hardware.
- 1 Enhanced security features available through either the System Setup program or the Resource Configuration Utility, including a user password and a supervisor password.
- 1 Diagnostics for evaluating your computer's components and devices. For information on using the system diagnostics, see "[Using the Dell OpenManage Server Assistant CD](#)" or see "Running the Dell Diagnostics" in your *Installation and Troubleshooting Guide*.

Supported Operating Systems

Dell supports the following network operating systems for use on PowerEdge 4400 systems:

- 1 Windows NT Server 4.0, Service Pack 4 or later
- 1 NetWare 4.2 and 5.0

 **NOTE:** Installation service and support for other operating systems are available through Dell Plus. For more information, see "Getting Help" in your *Installation and Troubleshooting Guide*.

Front Panel

The following controls and indicators are behind the external drive door on the computer's front panel (see Figure 1).

Figure 1. Front-Panel Features

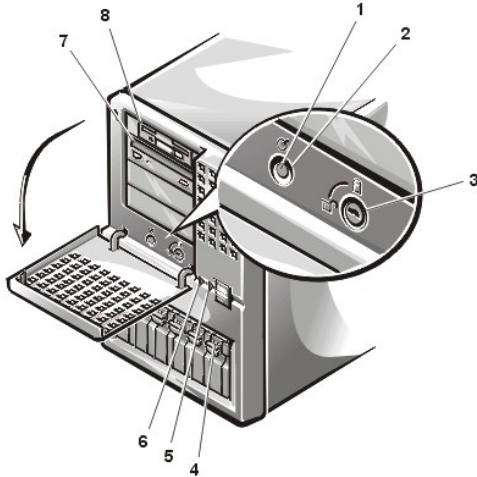

- 1 Power indicator
- 2 Power button
- 3 Hard-disk drive keylock
- 4 Drive access indicators
- 5 Fan/thermal status indicator
- 6 Power supply status indicator
- 7 CD-ROM drive
- 8 Diskette drive

- 1 The power button on the front panel controls the AC power input to the system's power supply.
- 1 The green power indicator in the center of the power button lights up when the power supply is turned on and the system is receiving DC power.

The following indicators are on the system's front panel.

- 1 The green fan/temperature status indicator blinks amber when a fan failure is detected or temperature is out of bounds.
- 1 The green power supply status indicator blinks amber if a fault is detected with any of the power supplies or any system voltages.

The three indicator lights on each of the SCSI hard-disk drive carriers provide the following information:

- 1 The green hard-disk drive online indicator lights up when the hard-disk drive is receiving power.
- 1 The green hard-disk drive activity indicator lights up when data is being transferred to or from the hard-disk drive.
- 1 The amber hard-disk drive failure indicator blinks if a hard-disk drive failure is detected.

Figure 2. Hard-Disk Drive Indicators

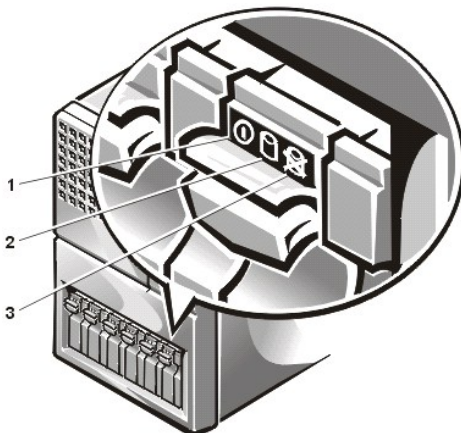

- 1 Hard-disk drive online indicator
 - 2 Hard-disk drive activity indicator
 - 3 Hard-disk drive failure indicator
-

Connecting External Devices

You can connect various external devices, such as a mouse and printer, to the I/O ports and connectors on the computer's back panel (see Figure 3).

Figure 3. Back-Panel Features

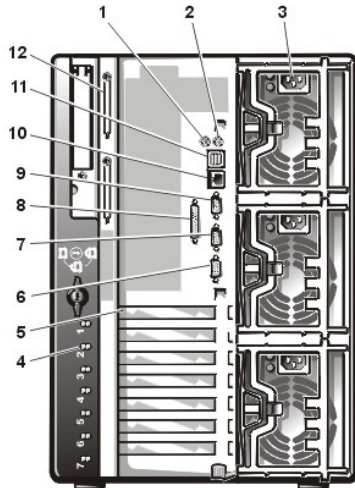

- 1 Mouse connector
- 2 Keyboard connector
- 3 Power supplies (2 standard, 3 optional. Top supply is supply #1)
- 4 Hot-plug PCI indicators (4) (pushbutton switches are internally accessible)
- 5 Expansion slots (7)
- 6 Video connector
- 7 Serial port 2
- 8 Parallel port connector
- 9 Serial port 1
- 10 NIC connector
- 11 USB connectors (2)
- 12 Optional external SCSI connectors (2)

The system BIOS detects the presence of external devices when you boot or reboot your system. When you connect external devices to your computer, follow these guidelines:

- 1 Check the documentation that accompanied the device for specific installation and configuration instructions.

For example, most devices must be connected to a particular I/O port or connector to operate properly. Also, external devices such as a mouse or printer usually require that you load software files called device drivers into memory before they will work. These software drivers help the computer recognize an external device and direct its operation. Device drivers of this type are normally included with your operating system software.

- 1 Always attach external devices while your computer is turned off. Then turn on any external devices before turning on the computer unless the documentation for the device specifies otherwise. (If the computer does not seem to recognize the device, try turning on the computer before turning on the device.)

For information about enabling, disabling, or configuring I/O ports and connectors, see "[Using the System Setup Program](#)" or "[Using the Resource Configuration Utility](#)." For detailed descriptions and illustrations of each port and connector on the I/O panel, see "[I/O Ports and Connectors](#)."

Preventing Unauthorized Access Inside the Computer

A keylock behind the door on the front bezel prevents unauthorized access to the hot-pluggable hard-disk drives. A second lock on the back of the unit prevents the top cover from being removed.

PowerEdge 4400 systems also include a system intrusion switch that signals appropriate server management software if the top cover is opened.

Getting Help

If at any time you do not understand a procedure described in this guide, or if your system does not perform as expected, Dell provides a number of tools to help you. For more information on these help tools, see "Getting Help" in your *Installation and Troubleshooting Guide*.

[Back to Contents Page](#)

I/O Ports and Connectors: Dell™ PowerEdge™ 4400 Systems User's Guide

[Overview](#)

[I/O Ports and Connectors](#)

[Serial and Parallel Ports](#)

[Keyboard and Mouse Connectors](#)

[Video Connector](#)

[USB Connectors](#)

[Integrated Network Interface Controller Connector](#)

Overview

This section provides specific information about the input/output (I/O) ports and connectors on the back panel of the computer.

I/O Ports and Connectors

The I/O ports and connectors on the back panel of the computer are the gateways through which the computer system communicates with external devices, such as a keyboard, mouse, printer, and monitor. Figure 1 identifies the I/O ports and connectors for your system.

Figure 1. I/O Ports and Connectors

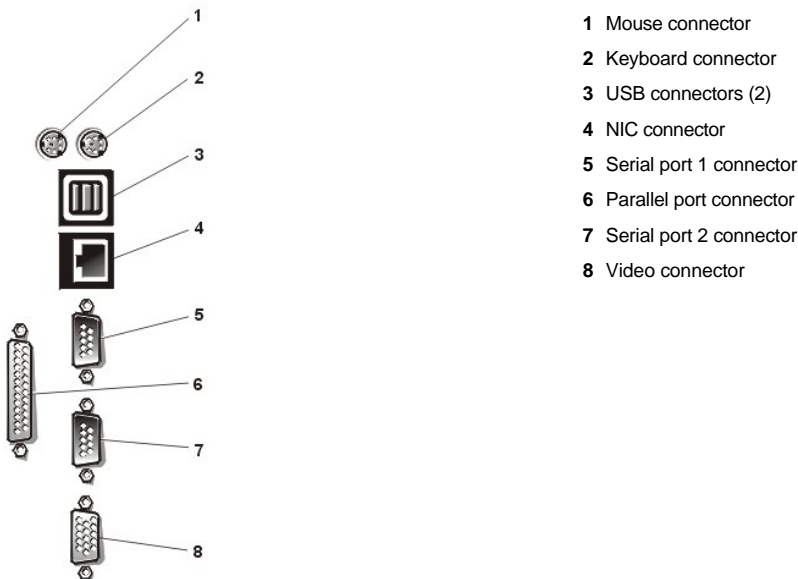

Serial and Parallel Ports

The two integrated serial ports use 9-pin D-subminiature connectors on the back panel. These ports support devices such as external modems, printers, plotters, and mice that require serial data transmission (the transmission of data one bit at a time over one line).

Most software uses the term COM (for communications) plus a number to designate a serial port (for example, COM1 or COM2). The default designations of your computer's integrated serial ports are COM1 and COM2. COM1 is the bottom connector; COM2 is on the top.

The integrated parallel port uses a 25-pin D-subminiature connector on the computer's back panel. This I/O port sends data in parallel format (where eight data bits, or one byte, are sent simultaneously over eight separate lines in a single cable). The parallel port is used primarily for printers.

Most software uses the term LPT (for line printer) plus a number to designate a parallel port (for example, LPT1). The default designation of the computer's integrated parallel port is LPT1.

Port designations are used, for example, in software installation procedures that include a step in which you identify the port to which a printer is attached, thus telling the software where to send its output. (An incorrect designation prevents the printer from printing or causes scrambled print.)

Adding an Expansion Card Containing Serial or Parallel Ports

The computer system has an autoconfiguration capability for the serial ports. This feature lets you add an expansion card containing a serial port that has the same designation as one of the integrated ports, without having to reconfigure the card. When the computer detects the duplicate serial port on the expansion card, it remaps (reassigns) the integrated port to the next available port designation.

Both the new and the remapped COM ports share the same interrupt request (IRQ) setting, as follows:

COM1, COM3: IRQ4 (shared setting)
COM2, COM4: IRQ3 (shared setting)

These COM ports have the following I/O address settings:

COM1: 3F8h
COM2: 2F8h
COM3: 3E8h
COM4: 2E8h

For example, if you add an internal modem card with a port configured as COM1, the computer then sees logical COM1 as the address on the modem card. It automatically remaps the integrated serial port that was designated as COM1 to COM3, which shares the COM1 IRQ setting. (Note that when you have two COM ports sharing an IRQ setting, you can use either port as necessary but you may not be able to use them both at the same time.) If you install one or more expansion cards with serial ports designated as COM1 and COM3, the corresponding integrated serial port is disabled.

Before adding a card that remaps the COM ports, check the documentation that accompanied your software to make sure that the software can be mapped to the new COM port designation.

To avoid autoconfiguration, you may be able to reset jumpers on the expansion card so that the card's port designation changes to the next available COM number, leaving the designation for the integrated port as is. Alternatively, you can disable the integrated ports through the System Setup program. The documentation for your expansion card should provide the card's default I/O address and allowable IRQ settings. It should also provide instructions for readdressing the port and changing the IRQ setting, if necessary.

If you add an expansion card containing, for example a parallel port configured as LPT1 (IRQ7, I/O address 378h), you must go into the [system setup](#) program to remap the integrated parallel port.

For general information on how your operating system handles serial and parallel ports, and for more detailed command procedures, see your operating system documentation.

Serial Port Connectors

If you reconfigure your hardware, you may need pin number and signal information for the serial port connectors. [Figure 2](#) illustrates the pin numbers for the serial port connectors and defines the pin assignments and interface signals for the serial port connector.

Figure 2. Pin Numbers for the Serial Port Connectors



Pin	Signal	I/O	Definition
1	DCD	I	Data carrier detect
2	SIN	I	Serial input
3	SOUT	O	Serial output
4	DTR	O	Data terminal ready
5	GND	N/A	Signal ground
6	DSR	I	Data set ready
7	RTS	O	Request to send
8	CTS	I	Clear to send
9	RI	I	Ring indicator
Shell	N/A	N/A	Chassis ground

Parallel Port Connector

If you reconfigure your hardware, you may need pin number and signal information for the parallel port connector. [Figure 3](#) illustrates the pin numbers for the parallel port connector and defines the pin assignments and interface signals for the parallel port connector.

Figure 3. Pin Numbers for the Parallel Port Connector



Pin	Signal	I/O	Definition
1	STB#	I/O	Strobe
2	PD0	I/O	Printer data bit 0
3	PD1	I/O	Printer data bit 1
4	PD2	I/O	Printer data bit 2
5	PD3	I/O	Printer data bit 3
6	PD4	I/O	Printer data bit 4
7	PD5	I/O	Printer data bit 5
8	PD6	I/O	Printer data bit 6

9	PD7	I/O	Printer data bit 7
10	ACK#	I	Acknowledge
11	BUSY	I	Busy
12	PE	I	Paper end
13	SLCT	I	Select
14	AFD#	O	Automatic feed
15	ERR#	I	Error
16	INIT#	O	Initialize printer
17	SLIN#	O	Select in
18-25	GND	N/A	Signal ground

Keyboard and Mouse Connectors

The system uses a Personal System/2 (PS/2)-style keyboard and supports a PS/2-compatible mouse. Cables from both devices attach to 6-pin, miniature *Deutsche Industrie Norm* (DIN) connectors on the back panel of your computer.

Mouse driver software can give the mouse priority with the microprocessor by issuing IRQ12 whenever a new mouse movement is detected. The driver software also passes along the mouse data to the application program that is in control.

Keyboard Connector

If you reconfigure your hardware, you may need pin number and signal information for the keyboard connector. [Figure 4](#) illustrates the pin numbers for the keyboard connector and defines the pin assignments and interface signals for the keyboard connector.

Figure 4. Pin Numbers for the Keyboard Connector



Pin	Signal	I/O	Definition
1	KBDATA	I/O	Keyboard data
2	NC	N/A	No connection
3	GND	N/A	Signal ground
4	FVcc	N/A	Fused supply voltage
5	KBCLK	I/O	Keyboard clock
6	NC	N/A	No connection
Shell	N/A	N/A	Chassis ground

Mouse Connector

If you reconfigure your hardware, you may need pin number and signal information for the mouse connector. [Figure 5](#) illustrates the pin numbers for the mouse connector, and defines the pin assignments and interface signals for the mouse connector.

Figure 5. Pin Numbers for the Mouse Connector



Pin	Signal	I/O	Definition
1	MFDATA	I/O	Mouse data
2	NC	N/A	No connection
3	GND	N/A	Signal ground
4	FVcc	N/A	Fused supply voltage
5	MFCLK	I/O	Mouse clock
6	NC	N/A	No connection
Shell	N/A	N/A	Chassis ground

Video Connector

The system uses a 15-pin high-density D-subminiature connector on the back panel for attaching a video graphics array (VGA)-compatible monitor to your computer. The video circuitry on the system board synchronizes the signals that drive the red, green, and blue electron guns in the monitor.

 **NOTE:** Installing a video card automatically disables the system's integrated video subsystem.

If you reconfigure your hardware, you may need pin number and signal information for the video connector. [Figure 6](#) illustrates the pin numbers for the video connector, and defines the pin assignments and interface signals for the video connector.

Figure 6. Pin Numbers for the Video Connector



Pin	Signal	I/O	Definition
1	RED	O	Red video
2	GREEN	O	Green video
3	BLUE	O	Blue video
4	NC	N/A	No connection
5-8, 10	GND	N/A	Signal ground
9	VCC	N/A	Vcc
11	NC	N/A	No connection
12	DDC data out	O	Monitor detect data
13	HSYNC	O	Horizontal synchronization
14	VSYNC	O	Vertical synchronization
15	DDC clock out	O	Monitor detect clock
Shell	N/A	N/A	Chassis ground

USB Connectors

Your system contains two Universal Serial Bus (USB) connectors for attaching USB-compliant devices. USB devices are typically peripherals such as mice, printers, keyboards, and computer speakers.

NOTICE: Do not attach a USB device or a combination of USB devices that draw a maximum current over 500 milliamperes (mA) per channel or +5 volts (V). Attaching devices that exceed this threshold may cause the USB ports to shut down. See the documentation that accompanied the USB devices for their maximum current ratings.

If you reconfigure your hardware, you may need pin number and signal information for the USB connectors. [Figure 7](#) illustrates the USB connector, and defines the pin assignments and interface signals for the USB connector.

Figure 7. USB Connector

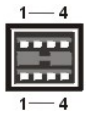

Pin	Signal	I/O	Definition
1	Vcc	N/A	Supply voltage
2	DATA	I	Data in
3	+DATA	O	Data out
4	GND	N/A	Signal ground

Integrated Network Interface Controller Connector

Your system has an integrated 10/100–megabit-per-second (Mbps) network interface controller (NIC). The NIC provides all the functions of a separate network expansion card and supports both the 10BASE-T and 100BASE-TX Ethernet standards.

The NIC includes a Wakeup On LAN feature that enables the computer to be started by a special local area network (LAN) signal from a server management console. Wakeup On LAN provides remote computer setup, software downloading and installation, file updates, and asset tracking after hours and on weekends when LAN traffic is typically at a minimum.

Network Cable Requirements

Your computer's RJ45 NIC connector is designed for attaching an unshielded twisted pair (UTP) Ethernet cable equipped with standard RJ45-compatible plugs. Press one end of the UTP cable into the NIC connector until the plug snaps securely into place. Connect the other end of the cable to an RJ45 jack wall plate or to an RJ45 port on a UTP concentrator or hub, depending on your network configuration. Observe the following cabling restrictions for 10BASE-T and 100BASE-TX networks.

NOTICE: To avoid line interference, voice and data lines must be in separate sheaths.

- 1 For 10BASE-T networks, use Category 3 or greater wiring and connectors.
- 1 For 100BASE-TX networks, use Category 5 or greater wiring and connectors.
- 1 The maximum cable run length (from a workstation to a concentrator) is 328 feet (ft) (100 meters [m]).
- 1 For 10BASE-T networks, the maximum number of daisy-chained concentrators on one network segment is four.

[Back to Contents Page](#)

Maintaining the System: Dell™ PowerEdge™ 4400 Systems User's Guide

[Overview](#)

[Environmental Factors](#)

[Data Preservation](#)

[Power Protection Devices](#)

[Cleaning System Components](#)

Overview

Proper use of preventive maintenance procedures can keep the system in top operating condition and minimize the need for costly, time-consuming service procedures. This file contains maintenance procedures that you should perform regularly.

Data Preservation

Everyone inadvertently deletes files at one time or another. Also, hard-disk drives can fail after extended use, so it is not a question of whether you will eventually lose data, but when. To avoid such loss of data, you should regularly make backup copies of all hard-disk drive files. Frequent, regular backups are a must for anyone using a hard-disk drive.

Scheduling Backups

The frequency with which backups should be made depends on the amount of storage space on a hard-disk drive and the volatility of the data contained on the drive. Heavily used systems require more frequent backups than systems in which files are seldom changed.

Dell recommends that you back up the hard-disk drive at least once a week, with a daily backup of those files known to have been changed. Following these guidelines ensures the loss of no more than a day's work in the event of a hard-disk drive failure or if you inadvertently delete one or more important files.

As further insurance against data losses, you should keep duplicate copies of the weekly and monthly backups at an off-site location. Doing this ensures that you lose no more than a week's work, even if one of the on-site backups becomes corrupted.

Backup Devices

Tape drives are fast, convenient, and reliable devices that can back up data at rates of up to 1.5 megabytes per second (MB/sec) (sustained, without data compression) and can often run unattended. Dell offers tape drives with storage capacities in the range of 20 to 70 gigabytes (GB) per tape cartridge and recommends these drives and their associated backup software for use as system backup devices.

As a last resort, you can back up a hard-disk drive's contents on diskettes, a method that is both time-consuming and prone to human error. Also, backing up a full 4-GB hard-disk drive requires approximately 277 diskettes (when using 1.44-MB diskettes), 334 diskettes (when using 1.2-MB diskettes), or 139 diskettes (when using 2.88-MB diskettes). Therefore, if it is absolutely necessary to use diskettes as backup devices, any unwanted hard-disk drive files should be deleted before a backup procedure is started.

Recovering Data

Some hard-disk drive failures are recoverable. In these cases you may be able to recover all lost data if the proper utility software is available. Even losses such as accidentally deleted files or accidental reformatting of a hard-disk drive can be reversed with these utilities.

If the system is running the MS-DOS® operating system, many apparent data loss problems are due to corruption or erasure of the hard-disk drive's master boot record (MBR), MS-DOS boot sector, or file allocation table (FAT); that is, accidental deletion of files or accidental reformatting of the hard-disk drive alters the MS-DOS boot sector, the FAT, and the root directory.

However, such accidents do not actually erase the contents of the hard-disk drive files until new data is written to the sectors containing these files. With software such as the Norton Utilities, Mace Utilities, or PC-Tools Deluxe, the data stored in these areas can often be restored, meaning that you can recover most, if not all, of the data.

Unlike using the format command on a hard-disk drive, using format on a diskette completely erases all the data on the diskette unless you use the diskette format program included in the Mace Utilities.

For a complete description of data recovery procedures and the software needed to perform them, see *The Paul Mace Guide to Data Recovery*, published by Brady.

Cleaning System Components

An exhaust fan in the power supply cools the power supply and system by drawing air in through various openings in the system and blowing it out the back. However, the fan also draws dust and other particles into the system, causing contaminant buildup, which results in an increase in the system's internal temperature and interferes with the operation of various system components.

To avoid these conditions, Dell recommends keeping your work environment clean to reduce the amount of dust and dirt around the system, thereby reducing the amount of contaminants drawn into the system by the power supply fan. In particular, you should keep the exterior of your system and monitor clean, and you should use a commercially available diskette-drive head-cleaning kit to remove contaminants inside your diskette drives.

Recommended Tools and Accessories

Dell recommends that you use the following tools and accessories when you clean the system:

- 1 **A wrist-grounding strap** — The proper use of a wrist-grounding strap reduces the effect of electrostatic discharge (ESD), which can damage certain system components. To use a wrist-grounding strap, place the strap around your wrist and attach the other end of the strap to an unpainted metal surface in the chassis, such as the power supply bracket, that is connected to chassis ground.
- 1 **A liquid dishwashing detergent** — Use a mixture of one part liquid dishwashing detergent and three parts water to clean the exterior of the system, monitor, and keyboard. You can also add fabric softener to produce an antistatic solution that prevents dust from being attracted to the monitor screen.
- 1 **A soft, lint-free cleaning cloth** — Moisten the cleaning cloth with the dishwashing detergent solution to clean the exterior of the system.
- 1 **A nonabrasive diskette-drive head-cleaning kit** — Dell recommends that you use a kit that contains pretreated diskettes in individually sealed packages. These kits ensure that the cleaning solution is applied evenly over the entire diskette-drive head surface, and they prevent contamination of the heads by exposure to foreign substances.
- 1 **A small vacuum cleaner with a brush attachment** — Use the vacuum cleaner to remove dust and dirt from the exterior of the system and keyboard.

Cleaning the System, Monitor, and Keyboard Exteriors

A conventional monitor or keyboard cover minimizes the accumulation of dust and other debris inside the monitor and keyboard when they are not in use. Also, commercially available keyboard membrane covers make it possible to use the keyboard while providing protection against foreign particles.

However, regardless of any protective covers, the monitor and keyboard must be cleaned occasionally. To clean the exterior of the system, monitor, and keyboard, perform the following steps:

Turn off the system, monitor, and any other attached peripherals, and disconnect them from their electrical outlets.

1. Use a vacuum cleaner to remove any dust from the slots and holes on the system and between the keys on the keyboard.
2. Moisten a soft cleaning cloth with a solution of three parts water and one part liquid dishwashing detergent. Do not soak the cloth in the solution; you must not let the solution drip inside the system or keyboard.
3. Use the moistened cloth to wipe the system cover, the keyboard, and the exterior of the monitor, including the screen.

Cleaning Drives

 **CAUTION: Do not attempt to clean drive heads with a swab. You may accidentally misalign the heads, rendering the drive inoperable.**

You can clean the heads of your diskette drives by using a commercially available diskette-drive head-cleaning kit. These kits include diskettes pretreated with a chemical solution to nonabrasively remove contaminants that accumulate on the drive heads during normal operation.

If the kit does not contain instructions, insert one of the pretreated diskettes into a diskette drive and turn on the system. After 20 or 30 seconds, remove the diskette from the drive. Repeat this procedure for each diskette drive in the system.

Environmental Factors

This section discusses various environmental factors that can adversely affect system performance and longevity.

Temperature

Temperature extremes can cause a variety of problems, including premature aging and failure of chips or mechanical failure of devices. Extreme temperature fluctuations can cause chips to become loose in their sockets and can cause expansion and contraction of disk drive platters, resulting in read or write data errors. When you perform a low-level format operation on a hard-disk drive, it is important to ensure that the drive's surrounding temperature is at or near the temperature at which the drive will be operated. Failure to do so can result in relocation of the tracks on the disk platters.

To minimize the negative effects of temperature on system performance, follow these guidelines:

- 1 Ensure that the system is operated in an environment no colder than 10° Celsius (C) (50° Fahrenheit [F]) or hotter than 35° C (95° F).
- 1 Ensure that the system has adequate ventilation. Do not place it within a closed-in wall unit or on top of cloth material, which can act as insulation. Do not place it where it will receive direct sunlight, particularly in the afternoon. Do not place it next to a heat source of any kind, including heating vents during winter.

Adequate ventilation is particularly important at high altitudes. System performance may not be optimum when the system is operating at high temperatures as well as high altitudes.

- 1 Make sure that all slots and openings on the system remain unobstructed, especially the fan vent on the back of the system.
- 1 Clean the system at regular intervals to avoid any buildup of dust and debris, which can cause a system to overheat.
- 1 If the system has been exposed to abnormally cold temperatures, allow a two-hour warm-up period to bring it up to normal operating temperature before turning it on. Failure to do so may cause damage to internal components, particularly the hard-disk drive.
- 1 If intermittent system failures are noticed, try reseating any socketed chips, which might have become loose due to temperature fluctuations.

Humidity

High-humidity conditions can cause moisture migration and penetration into the system. This moisture can cause corrosion of internal components and degradation of properties such as electrical resistance, thermal conductivity, physical strength, and size. Extreme moisture buildup inside the system can result in electrical shorts, which can cause serious damage to the system.

Each Dell system is rated to operate at 8 to 80 percent relative humidity, with a humidity gradation of 10 percent per hour. In storage, a Dell system can withstand from 5 to 95 percent relative humidity.

Buildings in which climate is controlled by air-conditioning in the warmer months and by heat during the colder months usually maintain an acceptable level of humidity for system equipment. However, if a system is located in an unusually humid location, a dehumidifier can be used to maintain the humidity within an acceptable range.

Altitude

Operating a system at high altitude (low pressure) reduces the efficiency of forced and convection cooling and can result in electrical problems related to arcing and corona effects. This condition can also cause sealed components with internal pressure, such as electrolytic capacitors, to fail or perform at reduced efficiency.

Each Dell system is rated to operate at altitudes from -16 to 3048 meters (m) (-50 to 10,000 feet [ft]) and can be stored at altitudes of -16 to 10,600 m (-50 to 35,000 ft).

Dust and Particles

A clean operating environment can greatly reduce the negative effects of dust and other particles, which act as insulators and interfere with the operation of a system's mechanical components. Also, in addition to regular cleaning, you should follow these guidelines to deter contamination of the system equipment:

- 1 Do not permit smoking anywhere near the system.
- 1 Do not permit food or drink near the system.
- 1 Use dust covers when the system is not in use.
- 1 Keep all diskettes in a closed diskette box when not in use.
- 1 Close windows and outside doors to keep out airborne particles.

Corrosion

The oil from a person's fingers or prolonged exposure to high temperature or humidity can corrode the gold-plated edge connectors and pin connectors on various devices in the system. This corrosion on system connectors is a gradual process that can eventually lead to intermittent failures of electrical circuits.

To prevent corrosion, you should avoid touching contacts on boards and cards. Protecting the system from corrosive elements is especially important in moist and salty environments, which tend to promote corrosion. Also, as a further deterrent to corrosion, the system should not be used in extreme temperatures, as explained in "[Temperature](#)."

ESD

ESD results from the buildup of static electricity on the human body and certain other objects. This static electricity is often produced by simple movements such as walking across a carpet. ESD is a discharge of a static electrical charge that occurs when a person whose body contains such a charge touches a component in the system. This static discharge can cause components, especially chips, to fail. ESD is a problem particularly in dry environments where the relative humidity is below 50 percent. To reduce the effects of ESD, you should observe the following guidelines:

- 1 When working inside the system, wear a wrist-grounding strap. If a wrist-grounding strap is unavailable, touch an unpainted metal surface on the chassis periodically to neutralize any static charge.
- 1 If at all possible, stand on a concrete floor while working inside the system.
- 1 Use an antistatic floor mat when working inside the system.
- 1 If it is necessary to work in a carpeted area, spray the carpet with an antistatic spray and allow it to dry before beginning to work inside the

system.

- 1 Keep components in their antistatic packaging until they are installed.
- 1 Avoid wearing clothing made of wool or synthetic materials.

Electromagnetic and Radio Frequency Interference

Electromagnetic interference (EMI) and radio frequency interference (RFI) from a system can adversely affect devices such as radio and television (TV) receivers operating near the system. Radio frequencies emanating from a system can also interfere with cordless and low-power telephones. Conversely, RFI from high-power telephones can cause spurious characters to appear on the system's monitor screen.

RFI is defined as any EMI with a frequency above 10 kilohertz (kHz). This type of interference can travel from the system to other devices through the power cable and power source or through the air like transmitted radio waves. The Federal Communications Commission (FCC) publishes specific regulations to limit the amount of EMI and RFI emitted by computing equipment. Each Dell system meets these FCC regulations.

To reduce the possibility of EMI and RFI, follow these guidelines:

- 1 Operate the system only with the system cover installed.
- 1 Ensure that all expansion slots are covered either by a card-mounting bracket or by a metal filler bracket and that all drive bays have a drive and/or a metal insert installed. These brackets and metal inserts are available from Dell.
- 1 Ensure that the screws on all peripheral cable connectors are securely fastened to their corresponding connectors on the back of the system.
- 1 Always use shielded cables with metal connector shells for attaching peripherals to the system.

To prevent the possibility of RFI from a system affecting TV reception, follow these guidelines:

- 1 Keep any TV set at least 6 ft away from the system.
- 1 Use cable TV when possible.
- 1 Use a directional outdoor TV antenna.
- 1 Attach line filters to the TV set.
- 1 Use 75-ohm coaxial cable for the TV set rather than twin-lead antenna wire.
- 1 If interference occurs, rotate the system or the TV set 90 degrees.

Magnetism

Because they store data magnetically, diskettes and hard-disk drives are extremely susceptible to the effects of magnetism. Diskettes should never be stored near magnetic sources such as the following:

- 1 Monitors
- 1 TV sets
- 1 Printers
- 1 Telephones with real bells
- 1 Fluorescent lights

Shock and Vibration

Excessive shock can damage the function, external appearance, and physical structure of a system. Each Dell system has been designed to operate properly even after withstanding a minimum of six consecutively executed shock pulses in the positive and negative x, y, and z axes (one pulse on each side of the system). Each shock pulse can measure up to 41 gravities (G) for up to 2 milliseconds (ms). In storage, the system can withstand shock pulses of 71 G for 2 ms.

Excessive vibration can cause the same problems as mentioned earlier for shock, as well as causing components to become loose in their sockets or connectors. Systems can be subject to significant vibration when being transported by vehicle or when operated in an environment with machinery that causes vibration.

Each Dell system, when operating, is designed to withstand 0.25 G (half-sine wave) at a sweep of 3 to 200 hertz (Hz) for 30 minutes. In storage, the system can withstand 0.5 G at 3 to 200 Hz for 30 minutes.

Power Source Interruptions

Systems are especially sensitive to variations in voltage supplied by the AC power source. Over-voltage, undervoltage, and transients (or spikes) can erase data from memory or even cause components to fail. To protect against these types of problems, power cables should always be properly grounded and one or both of the following methods should be used:

- 1 Use one of the power protection devices described in the following section, "[Power Protection Devices](#)."
- 1 Place the system on a dedicated power circuit (rather than sharing a circuit with other heavy electrical equipment). In general, do not allow the system to share a circuit with any of the following:
 - 1 Copier machines
 - 1 Air conditioners
 - 1 Vacuum cleaners
 - 1 Space heaters
 - 1 Power tools
 - 1 Teletype machines
 - 1 Adding machines
 - 1 Laser printers
 - 1 Facsimile machines
 - 1 Any other motorized equipment

Besides these appliances, the greatest threats to a system's supply of power are surges or blackouts caused by electrical storms. Whenever possible, turn off the system and any peripherals and unplug them from their power sources during thunderstorms.

If a blackout occurs—even a temporary one—while the system is turned on, turn off the system immediately and disconnect it from the electrical outlet. Leaving the system on may cause problems when the power is restored; all other appliances left on in the area can create large voltage spikes that can damage the system.

Power Protection Devices

A number of devices are available that protect against power problems such as power surges, transients, and power failures. The following subsections describe some of these devices.

Surge Protectors

Surge protectors are available in a variety of types and usually provide a level of protection commensurate with the cost of the device. Surge protectors prevent voltage spikes, such as those caused during an electrical storm, from entering a system through the electrical outlet. Surge protectors, however, do not offer protection against brownouts, which occur when the voltage drops more than 20 percent below the normal AC line voltage level.

Line Conditioners

Line conditioners go beyond the overvoltage protection of surge protectors. Line conditioners keep a system's AC power source voltage at a fairly constant level and, therefore, can handle brownouts. Because of this added protection, line conditioners cost more than surge protectors—up to several hundred dollars. However, these devices cannot protect against a complete loss of power.

Uninterruptible Power Supplies

Uninterruptible power supply (UPS) systems offer the most complete protection against variations in power because they use battery power to keep the system running when AC power is lost. The battery is charged by the AC power while it is available, so once AC power is lost, the battery can provide power to the system for a limited amount of time—from 15 minutes to an hour or so—depending on the UPS system.

UPS systems range in price from a few hundred dollars to several thousand dollars, with the more expensive units allowing you to run larger systems for a longer period of time when AC power is lost. UPS systems that provide only 5 minutes of battery power let you conduct an orderly shutdown of the system, but are not intended to provide continued operation. Surge protectors should be used with all UPS systems, and the UPS system should be Underwriters Laboratories (UL) safety-approved.

[Back to Contents Page](#)

[Back to Contents Page](#)

Preface: Dell™ PowerEdge™ 4400 Systems User's Guide

[About This Guide](#)

[Other Documents You May Need](#)

[Warranty and Return Policy Information](#)

[Typographical Conventions](#)

About This Guide

This guide is intended for anyone who uses the Dell PowerEdge 4400 computer systems. The guide can be used by both first-time and experienced computer users who want to learn about the features and operation of the systems or who want to upgrade their computers. The sections are summarized as follows:

- 1 ["Introduction"](#) — Overview of system features, description of indicators on the front panel, and general discussion of connecting external devices to the system back panel
 - 1 ["Using the Dell OpenManage Server Assistant CD"](#) — Instructions on using the utilities, diagnostics, and online documentation, and installing video drivers for the operating system
 - 1 ["Installing and Configuring SCSI Drivers"](#) — Requirements for small computer system interface (SCSI) device drivers (if any) for a particular system configuration or operating system
 - 1 ["Using the System Setup Program"](#) — Configuration changes to the system and password features
 - 1 ["Using the Resource Configuration Utility"](#) — Configuration changes required whenever a Peripheral Component Interconnect (PCI) expansion card is added, removed, or repositioned in the computer, or when the memory size or settings for one of the integrated devices is changed
 - 1 ["Technical Specifications"](#) — Technical specifications of the PowerEdge 4400 systems
 - 1 ["I/O Ports and Connectors"](#) — Ports and connectors on the back panel of the PowerEdge 4400 systems
 - 1 ["Maintaining the System"](#) — Preventive maintenance procedures for the computer system
 - 1 ["Regulatory Notices"](#) — Regulatory agencies that have tested and approved PowerEdge 4400 systems
 - 1 ["Warranty, Return Policy, and Year 2000 Statement of Compliance"](#) — Warranty and return policy for PowerEdge 4400 systems and year 2000 compliance for Dell-branded hardware products
 - 1 ["Glossary"](#) — Definitions of terms, acronyms, and abbreviations used in this guide
-

Warranty and Return Policy Information

Dell Computer Corporation ("Dell") manufactures its hardware products from parts and components that are new or equivalent to new in accordance with industry-standard practices. For information about the Dell warranty for your system, see ["Warranty, Return Policy, and Year 2000 Statement of Compliance."](#)

Other Documents You May Need

In addition to this *User's Guide*, the following documentation is included with your system:

- 1 The *Installation and Troubleshooting Guide* provides instructions for installing system hardware and includes troubleshooting and diagnostic procedures for testing your computer system.
- 1 The *HP OpenView Network Node Manager Special Edition 1.1 With Dell OpenManage 3.1 User's Guide* describes the alert messages issued by the optional server management software.

You may also have one or more of the following documents:

- 1 Operating system documentation is included with the system if you ordered the operating system software from Dell. This documentation describes how to install (if necessary), configure, and use the operating system software.
- 1 The Dell PowerEdge 4400 rack installation documentation provides detailed instructions for installing the system in a rack.
- 1 Documentation is included with any options you purchase separately from the system. This documentation includes information that you need to configure and install these options in your Dell computer.
- 1 Technical information files—sometimes called "readme" files—may be installed on the hard-disk drive to provide last-minute updates about

technical changes to the system or advanced technical reference material intended for experienced users or technicians.

- 1 Documentation updates are sometimes included with the system to describe changes to the system or software. Always read these updates before consulting any other documentation because the updates often contain information that supersedes the information in the other documents.

Typographical Conventions

The following list defines (where appropriate) and illustrates typographical conventions used as visual cues for specific elements of text throughout this document:

- 1 *Interface components* are window titles, button and icon names, menu names and selections, and other options that appear on the monitor screen or display. They are presented in bold.

Example: Click **OK**.

- 1 *Keypcaps* are labels that appear on the keys on a keyboard. They are enclosed in angle brackets.

Example: <Enter>

- 1 *Key combinations* are series of keys to be pressed simultaneously (unless otherwise indicated) to perform a single function.

Example: <Ctrl><Alt><Enter>

- 1 *Commands* presented in lowercase bold are for reference purposes only and are not intended to be typed when referenced.

Example: "Use the **format** command to . . ."

In contrast, commands presented in the Courier New font are part of an instruction and intended to be typed.

Example: "Type `format a:` to format the diskette in drive A."

- 1 *Filenames* and *directory names* are presented in lowercase bold.

Examples: **autoexec.bat** and **c:\windows**

- 1 *Syntax lines* consist of a command and all its possible parameters. Commands are presented in lowercase bold; variable parameters (those for which you substitute a value) are presented in lowercase italics; constant parameters are presented in lowercase bold. The brackets indicate items that are optional.

Example: **del** [*drive:*][*path*] *filename* [*/p*]

- 1 *Command lines* consist of a command and may include one or more of the command's possible parameters. Command lines are presented in the Courier New font.

Example: `del c:\myfile.doc`

- 1 *Screen text* is a message or text that you are instructed to type as part of a command (referred to as a *command line*). Screen text is presented in the Courier New font.

Example: The following message appears on your screen:

`No boot device available`

Example: "Type `md c:\programs` and press <Enter>."

- 1 *Variables* are placeholders for which you substitute a value. They are presented in italics.

Example: DIMM_*x* (where *x* represents the DIMM socket designation).

[Back to Contents Page](#)

Regulatory Notices: Dell™ PowerEdge™ 4400 Systems User's Guide

- [Overview](#)
 - [FCC Notices \(U.S. Only\)](#)
 - [IC Notice \(Canada Only\)](#)
 - [CE Notice \(European Union\)](#)
 - [Battery Disposal](#)
 - [EN 55022 Compliance \(Czech Republic Only\)](#)
 - [VCCI Notice \(Japan Only\)](#)
 - [MOC Notice \(South Korea Only\)](#)
 - [Polish Center for Testing and Certification Notice](#)
 - [Wymagania Polskiego Centrum Badan i Certyfikacji](#)
 - [Pozostale instrukcje bezpieczenstwa](#)
 - [NOM Information \(Mexico Only\)](#)
 - [Información para NOM \(únicamente para México\)](#)
 - [BSMI Notice \(Taiwan Only\)](#)
-

Overview

Electromagnetic Interference (EMI) is any signal or emission, radiated in free space or conducted along power or signal leads, that endangers the functioning of a radio navigation or other safety service or seriously degrades, obstructs, or repeatedly interrupts a licensed radio communications service. Radio communications services include but are not limited to AM/FM commercial broadcast, television, cellular services, radar, air-traffic control, pager, and Personal Communication Services (PCS). These licensed services, along with unintentional radiators such as digital devices, including computer systems, contribute to the electromagnetic environment.

Electromagnetic Compatibility (EMC) is the ability of items of electronic equipment to function properly together in the electronic environment. While this computer system has been designed and determined to be compliant with regulatory agency limits for EMI, there is no guarantee that interference will not occur in a particular installation. If this equipment does cause interference with radio communications services, which can be determined by turning the equipment off and on, you are encouraged to try to correct the interference by one or more of the following measures:

- 1 Reorient the receiving antenna.
- 1 Relocate the computer with respect to the receiver.
- 1 Move the computer away from the receiver.
- 1 Plug the computer into a different outlet so that the computer and the receiver are on different branch circuits.

If necessary, consult a Technical Support representative of Dell Computer Corporation or an experienced radio/television technician for additional suggestions. You may find the FCC Interference Handbook, 1986, to be helpful. It is available from the U.S. Government Printing Office, Washington, DC 20402, Stock No. 004-000-00450-7 or on the World Wide Web at www.fcc.gov/Bureaus/Compliance/WWW/tvibook.html.

Dell computer systems are designed, tested, and classified for their intended electromagnetic environment. These electromagnetic environment classifications generally refer to the following harmonized definitions:

- 1 Class A is typically for business or industrial environments.
- 1 Class B is typically for residential environments.

Information Technology Equipment (ITE), including peripherals, expansion cards, printers, input/output (I/O) devices, monitors, and so on, that are integrated into or connected to the system should match the electromagnetic environment classification of the computer system.

A Notice About Shielded Signal Cables: Use only shielded cables for connecting peripherals to any Dell device to reduce the possibility of interference with radio communications services. Using shielded cables ensures that you maintain the appropriate EMC classification for the intended environment. For parallel printers, a cable is available from Dell Computer Corporation. If you prefer, you can order a cable from Dell Computer Corporation on the World Wide Web at <http://www.dell.com/products/dellware/index.htm>.

Most Dell computer systems are classified for Class B environments. To determine the electromagnetic classification for your system or device, refer to the following sections specific for each regulatory agency. Each section provides country-specific EMC/EMI or product safety information.

FCC Notices (U.S. Only)

Most Dell computer systems are classified by the Federal Communications Commission (FCC) as Class B digital devices. However, the inclusion of certain options can change the rating of some configurations to Class A. To determine which classification applies to your computer system, examine all FCC registration labels located on the bottom or back panel of your computer, on card-mounting brackets, and on the cards themselves. If any one of the labels carries a Class A rating, your entire system is considered to be a Class A digital device. If all labels carry an FCC Class B rating as distinguished by either an FCC ID number or the FCC logo (FC), your system is considered to be a Class B digital device.

Once you have determined your system's FCC classification, read the appropriate FCC notice. Note that FCC regulations provide that changes or modifications not expressly approved by Dell Computer Corporation could void your authority to operate this equipment.

This device complies with Part 15 of the FCC Rules. Operation is subject to the following two conditions:

- 1 This device may not cause harmful interference.
- 1 This device must accept any interference received, including interference that may cause undesired operation.

Class A

This equipment has been tested and found to comply with the limits for a Class A digital device pursuant to Part 15 of the FCC Rules. These limits are designed to provide reasonable protection against harmful interference when the equipment is operated in a commercial environment. This equipment generates, uses, and can radiate radio frequency energy and, if not installed and used in accordance with the manufacturer's instruction manual, may cause harmful interference with radio communications. Operation of this equipment in a residential area is likely to cause harmful interference, in which case you will be required to correct the interference at your own expense.

Class B

This equipment has been tested and found to comply with the limits for a Class B digital device pursuant to Part 15 of the FCC Rules. These limits are designed to provide reasonable protection against harmful interference in a residential installation. This equipment generates, uses, and can radiate radio frequency energy and, if not installed and used in accordance with the manufacturer's instruction manual, may cause interference with radio communications. However, there is no guarantee that interference will not occur in a particular installation. If this equipment does cause harmful interference to radio or television reception, which can be determined by turning the equipment off and on, you are encouraged to try to correct the interference by one or more of the following measures:

- 1 Reorient or relocate the receiving antenna.
- 1 Increase the separation between the equipment and the receiver.
- 1 Connect the equipment into an outlet on a circuit different from that to which the receiver is connected.
- 1 Consult the dealer or an experienced radio/television technician for help.

The following information is provided on the device or devices covered in this document in compliance with FCC regulations:

- 1 Model number: SML
- 1 Company name: Dell Computer Corporation
EMC Engineering Department
One Dell Way
Round Rock, Texas 78682 USA 512-338-4400

IC Notice (Canada Only)

Most Dell computer systems (and other Dell digital apparatus) are classified by the Industry Canada (IC) Interference-Causing Equipment Standard #3 (ICES-003) as Class B digital devices. To determine which classification (Class A or B) applies to your computer system (or other Dell digital apparatus), examine all registration labels located on the bottom or the back panel of your computer (or other digital apparatus). A statement in the form of "IC Class A ICES-3" or "IC Class B ICES-3" will be located on one of these labels. Note that Industry Canada regulations provide that changes or modifications not expressly approved by Dell Computer Corporation could void your authority to operate this equipment.

This Class B (or Class A, if so indicated on the registration label) digital apparatus meets the requirements of the Canadian Interference-Causing Equipment Regulations.

Cet appareil numérique de la Classe B (ou Classe A, si ainsi indiqué sur l'étiquette d'enregistrement) respecte toutes les exigences du Règlement sur le Matériel Brouilleur du Canada.

CE Notice (European Union)

Marking by the symbol  indicates compliance of this Dell system to the EMC Directive and the Low Voltage Directive of the European Union. Such marking is indicative that this Dell system meets the following technical standards:

- 1 EN 55022 — "Limits and Methods of Measurement of Radio Interference Characteristics of Information Technology Equipment."
- 1 EN 50082-1: 1992 — "Electromagnetic compatibility—Generic immunity standard Part 1: Residential, commercial, and light industry."
- 1 EN 60950 — "Safety of Information Technology Equipment."

 **NOTE:** EN 55022 emissions requirements provide for two classifications:

- 1 Class A is for typical commercial areas.
- 1 Class B is for typical domestic areas.

RF INTERFERENCE WARNING: This is a Class A product. In a domestic environment this product may cause radio frequency (RF) interference, in which case the user may be required to take adequate measures.

This Dell device is classified for use in a typical Class B domestic environment.

A "Declaration of Conformity" in accordance with the preceding directives and standards has been made and is on file at Dell Products Europe BV, Limerick, Ireland.



Battery Disposal

Your computer system uses nickel-metal hydride (NiMH) and lithium-ion batteries. The NiMH and lithium-ion batteries are long-life batteries, and it is very possible that you will never need to replace them. However, should you need to replace them, refer to the section about replacing the battery in your Dell documentation for instructions.

Do not dispose of the battery along with household waste. Contact your local waste disposal agency for the address of the nearest battery deposit site.



NOTE: Your system may also include circuit cards or other components that contain batteries. These batteries must also be disposed of in a battery deposit site. For information about such batteries, refer to the documentation for the specific card or component.

EN 55022 Compliance (Czech Republic Only)

This device belongs to Class B devices as described in EN 55022, unless it is specifically stated that it is a Class A device on the specification label. The following applies to devices in Class A of EN 55022 (radius of protection up to 30 meters). The user of the device is obliged to take all steps necessary to remove sources of interference to telecommunication or other devices.

Pokud není na typovém štítku počítače uvedeno, že spadá do třídy A podle EN 55022, spadá automaticky do třídy B podle EN 55022. Pro zařízení zařazená do třídy A (ochranné pásmo 30m) podle EN 55022 platí následující. Dojde-li k rušení telekomunikačních nebo jiných zařízení, je uživatel povinen provést taková opatření, aby rušení odstranil.

VCCI Notice (Japan Only)

Most Dell computer systems are classified by the Voluntary Control Council for Interference (VCCI) as Class B information technology equipment (ITE). However, the inclusion of certain options can change the rating of some configurations to Class A. ITE, including peripherals, expansion cards, printers, input/output (I/O) devices, monitors, and so on, integrated into or connected to the system, should match the electromagnetic environment classification (Class A or B) of the computer system.

To determine which classification applies to your computer system, examine the regulatory labels/markings (see [Figure 1](#) and [Figure 2](#)) located on the bottom or back panel of your computer. Once you have determined your system's VCCI classification, read the appropriate VCCI notice.

Class A ITE

この装置は、情報処理装置等電波障害自主規制協議会 (VCCI) の基準に基づくクラス A 情報技術装置です。この装置を家庭環境で使用すると電波妨害を引き起こすことがあります。この場合には使用者が適切な対策を講ずるよう要求されることがあります。

This is a Class A product based on the standard of the Voluntary Control Council for Interference (VCCI) for information technology equipment. If this equipment is used in a domestic environment, radio disturbance may arise. When such trouble occurs, the user may be required to take corrective actions.

Figure 1. VCCI Class A ITE Regulatory Mark

VCCI-A

Class B ITE

この装置は、情報処理装置等電波障害自主規制協議会（VCCI）の基準に基づくクラス B 情報技術装置です。この装置は家庭環境で使用することを目的としていますが、ラジオやテレビジョン受信機に近接して使用されると、受信障害を引き起こすことがあります。
取扱説明書に従って正しい取り扱いをしてください。

This is a Class B product based on the standard of the Voluntary Control Council for Interference (VCCI) for information technology equipment. If this equipment is used near a radio or television receiver in a domestic environment, it may cause radio interference. Install and use the equipment according to the instruction manual.

Figure 2. VCCI Class B ITE Regulatory Mark



MOC Notice (South Korea Only)

To determine which classification (Class A or B) applies to your computer system (or other Dell digital device), examine the South Korean Ministry of Communications (MOC) registration labels located on your computer (or other Dell digital device). The MOC label may be located separately from the other regulatory marking applied to your product. The English text, "EMI (A)," for Class A products, or "EMI (B)" for Class B products, appears in the center of the MOC label (see [Figure 3](#) and [Figure 4](#)).

NOTE: MOC emissions requirements provide for two classifications:

- 1 Class A devices are for business purposes.
- 1 Class B devices are for nonbusiness purposes.

Class A Device

장치 종류	사용자 안내문
A급 기기	이 장치는 업무용으로 전자파 적합등록을 한 장치이오니 판매자 또는 사용자는 이 점을 주의하시기 바라며 만약 잘못 판매 또는 구입하였을 때에는 가정용으로 교환하시기 바랍니다.

Please note that this device has been approved for business purposes with regard to electromagnetic interference. If you find that this device is not suitable for your use, you may exchange it for a nonbusiness device.

Figure 3. MOC Class A Regulatory Mark



Class B Device

장치 종류	사용자 안내문
B급 기기	이 장치는 가정용으로 전자파 적합등록을 한 장치로서 주거지역에서는 물론 모든 지역에서 사용할 수 있습니다.

Please note that this device has been approved for nonbusiness purposes and may be used in any environment, including residential areas.

Figure 4. MOC Class B Regulatory Mark



Polish Center for Testing and Certification Notice

The equipment should draw power from a socket with an attached protection circuit (a three-prong socket). All equipment that works together (computer, monitor, printer, and so on) should have the same power supply source.

The phasing conductor of the room's electrical installation should have a reserve short-circuit protection device in the form of a fuse with a nominal value no larger than 16 amperes (A).

To completely switch off the equipment, the power supply cable must be removed from the power supply socket, which should be located near the equipment and easily accessible.

A protection mark "B" confirms that the equipment is in compliance with the protection usage requirements of standards PN-93/T-42107 and PN-EN55022:1996.

Wymagania Polskiego Centrum Badań i Certyfikacji

Urządzenie powinno być zasilane z gniazda z przyłączonym obwodem ochronnym (gniazdo z kołkiem). Współpracujące ze sobą urządzenia (komputer, monitor, drukarka) powinny być zasilane z tego samego źródła.

Instalacja elektryczna pomieszczenia powinna zawierać w przewodzie fazowym rezerwową ochronę przed zwarciami, w postaci bezpiecznika o wartości znamionowej nie większej niż 16A (amperów).

W celu całkowitego wyłączenia urządzenia z sieci zasilania, należy wyjąć wtyczkę kabla zasilającego z gniazdka, które powinno znajdować się w pobliżu urządzenia i być łatwo dostępne.

Znak bezpieczeństwa "B" potwierdza zgodność urządzenia z wymaganiami bezpieczeństwa użytkownika zawartymi w PN-93/T-42107 i PN-89/E-06251.

Pozostałe instrukcje bezpieczeństwa

- Nie należy używać wtyczek adapterowych lub usuwać kołka obwodu ochronnego z wtyczki. Jeżeli konieczne jest użycie przedłużacza to należy użyć przedłużacza 3-żyłowego z prawidłowo połączonym przewodem ochronnym.
 - System komputerowy należy zabezpieczyć przed nagłymi, chwilowymi wzrostami lub spadkami napięcia, używając eliminatora przepięć, urządzenia dopasowującego lub bezzakłóceńowego źródła zasilania.
 - Należy upewnić się, aby nic nie leżało na kablach systemu komputerowego, oraz aby kable nie były umieszczone w miejscu, gdzie można byłoby na nie nadeptywać lub potykać się o nie.
 - Nie należy rozlewać napojów ani innych płynów na system komputerowy.
 - Nie należy wypychać żadnych przedmiotów do otworów systemu komputerowego, gdyż może to spowodować pożar lub porażenie prądem, poprzez zwarcie elementów wewnętrznych.
 - System komputerowy powinien znajdować się z dala od grzejników i źródeł ciepła. Ponadto, nie należy blokować otworów wentylacyjnych. Należy unikać kładzenia luźnych papierów pod komputer oraz umieszczania komputera w ciasnym miejscu bez możliwości cyrkulacji powietrza wokół niego.
-

NOM Information (Mexico Only)

The following information is provided on the device(s) described in this document in compliance with the requirements of the official Mexican standards (NOM):

Exporter:	Dell Computer Corporation One Dell Way Round Rock, TX 78682
Importer:	Dell Computer de México, S.A. de C.V. Rio Lerma No. 302 - 4° Piso Col. Cuauhtemoc 16500 México, D.F.
Ship to:	Dell Computer de México, S.A. de C.V. al Cuidado de Kuehne & Nagel de México S. de R.I. Avenida Soles No. 55 Col. Peñon de los Baños 15520 México, D.F.
Supply voltage:	115/230 VAC
Frequency:	60/50 Hz
Input current rating:	6.0/3.0 A

Información para NOM (únicamente para México)

La información siguiente se proporciona en el dispositivo o en los dispositivos descritos en este documento, en cumplimiento con los requisitos de la Norma Oficial Mexicana (NOM):

Exportador:	Dell Computer Corporation One Dell Way Round Rock, TX 78682
-------------	---

Importador: Dell Computer de México,
S.A. de C.V.
Rio Lerma No. 302 - 4° Piso
Col. Cuauhtemoc
16500 México, D.F.

Embarcar a: Dell Computer de México,
S.A. de C.V. al Cuidado
de Kuehne & Nagel de
México S. de R.I.
Avenida Soles No. 55
Col. Peñon de los Baños
15520 México, D.F.

Tensión alimentación: 115/230 VAC
Frecuencia: 60/50 Hz
Consumo de corriente: 6.0/3.0 A

BSMI Notice (Taiwan Only)

警告使用者：

這是甲類的資訊產品，在居住的環境中使用時，
可能會造成射頻干擾，在這種情況下，使用者會
被要求採取某些適當的對策。

[Back to Contents Page](#)

[Back to Contents Page](#)

Safety Instructions: Dell™ PowerEdge™ 4400 Systems User's Guide

- [Overview](#)
- [Notes, Notices, Cautions, and Warnings](#)
- [Safety Caution and Warnings](#)
- [Additional Safety Precautions](#)
- [When Working Inside Your Computer](#)
- [Protecting Against Electrostatic Discharge](#)
- [Ergonomic Computing Habits](#)

Overview

Use the following safety guidelines to ensure your own personal safety and to help protect your computer or storage system from potential damage.

Notes, Notices, Cautions, and Warnings

Throughout this guide, blocks of text may be accompanied by an icon and printed in bold type or in italic type. These blocks are notes, notices, cautions, and warnings, and they are used as follows:

 **NOTE:** A NOTE indicates important information that helps you make better use of your computer system.

NOTICE: A NOTICE indicates either potential damage to hardware or loss of data and tells you how to avoid the problem.

 **CAUTION:** A CAUTION indicates a potentially hazardous situation which, if not avoided, may result in minor or moderate injury.

 **WARNING:** A WARNING indicates a potentially hazardous situation which, if not avoided, could result in death or serious bodily injury.

Safety Caution and Warnings

Observe the following caution and warnings while servicing this system:

 **CAUTION:** There is a danger of a new battery exploding if it is incorrectly installed. Replace the battery only with the same or equivalent type recommended by the manufacturer. Discard used batteries according to the manufacturer's instructions.

 **WARNING:** The power supplies in your computer or storage system may produce high voltages and energy hazards, which can cause bodily harm. Only trained service technicians are authorized to remove the computer covers and access any of the components inside the computer. This warning applies to Dell PowerEdge 4xxx or higher servers and Dell PowerVault™ 2xxS storage systems.

 **WARNING:** This system may have more than one power supply cable. To reduce the risk of electrical shock, a trained service technician must disconnect all power supply cables before servicing the system.

DŮLEŽITÉ UPOZORNĚNÍ: Tento systém může mít více napájecích kabelů. Ke snížení rizika úrazu elektrickým proudem je nutné, aby školený servisní technik před prováděním servisu systému odpojil všechny napájecí kabely.

ADVARSEL: Dette system kan have mere end et strømforlyningskabel. For at reducere risikoen for elektrisk stød, bør en professionel servicetekniker frakoble alle strømforlyningskabler, før systemet serviceret.

VAROITUS: Tässä järjestelmässä voi olla useampi kuin yksi virtajohto. Sähköiskuvaaran pienentämiseksi ammattitaitoisen huoltohenkilön on irrotettava kaikki virtajohdot ennen järjestelmän huoltamista.

ПРЕДУПРЕЖДЕНИЕ: Данная система может иметь несколько кабелей электропитания. Во избежание электрического удара квалифицированный техник должен отключить все кабели электропитания прежде, чем приступить к обслуживанию системы.

OSTRZEŻENIE: System ten może mieć więcej niż jeden kabel zasilania. Aby zmniejszyć ryzyko porażenia prądem, przed naprawą lub konserwacją systemu wszystkie kable zasilania powinny być odłączone przez przeszkolonego technika obsługi.

ADVARSEL! Det er mulig at dette systemet har mer enn én strømledning. Unngå fare for støt: En erfaren servicetekniker må koble fra alle strømledninger før det utføres service på systemet.

VARNING: Detta system kan ha flera nätkablar. En behörig servicetekniker måste koppla loss alla nätkablar innan service utförs för att minska risken för elektriska stötar.

  **Additional Safety Precautions**

To reduce the risk of bodily injury, electrical shock, fire, and damage to the equipment, observe the following precautions.

General Precautions

Observe the following general precautions for using and working with your system:

- 1 Observe and follow service markings. Do not service any Dell product except as explained in your Dell system documentation. Opening or removing covers that are marked with the triangular symbol with a lightning bolt may expose you to electrical shock. Components inside these compartments should be serviced only by a Dell authorized service technician
- 1 If any of the following conditions occur, unplug the product from the electrical outlet and replace the part or contact your Dell authorized service provider:
 - o The power cable, extension cord, or plug is damaged.
 - o An object has fallen into the product.
 - o The product has been exposed to water.
 - o The product has been dropped or damaged.
 - o The product does not operate correctly when you follow the operating instructions.
- 1 Keep your system components away from radiators and heat sources. Also, do not block cooling vents.
- 1 Do not spill food or liquids on your system components, and never operate the product in a wet environment. If the computer gets wet, see the appropriate chapter in your troubleshooting guide or contact a Dell-authorized service provider.
- 1 Do not push any objects into the openings of your system components. Doing so can cause fire or electric shock by shorting out interior components.
- 1 Use the product only with Dell products or other Dell-approved equipment.
- 1 Allow the product to cool before removing covers or touching internal components.
- 1 Use the correct external power source. Operate the product only from the type of power source indicated on the electrical ratings label. If you are not sure of the type of power source required, consult your Dell service provider or local power company.
- 1 To help avoid damaging your system components, be sure the voltage selection switch (if provided) on the power supply is set to match the power available at your location:
 - o 115 volts (V)/60 hertz (Hz) in most of North and South America and some Far Eastern countries such as South Korea and Taiwan
 - o 100 V/50 Hz in eastern Japan and 100 V/60 Hz in western Japan
 - o 230 V/50 Hz in most of Europe, the Middle East, and the Far East

Also be sure that your monitor and attached peripherals are electrically rated to operate with the power available in your location.

- 1 Use only approved power cable(s). If you have not been provided with a power cable for your computer or storage system or for any AC-powered option intended for your system, purchase a power cable that is approved for use in your country. The power cable must be rated for the product and for the voltage and current marked on the product's electrical ratings label. The voltage and current rating of the cable should be greater than the ratings marked on the product.
- 1 To help prevent electric shock, plug the system components and peripheral power cables into properly grounded electrical outlets. These cables are equipped with three-prong plugs to help ensure proper grounding. Do not use adapter plugs or remove the grounding prong from a cable. If you must use an extension cord, use a three-wire cord with properly grounded plugs.
- 1 Observe extension cord and power strip ratings. Make sure that the total ampere rating of all products plugged into the extension cord or power strip does not exceed 80 percent of the extension cord or power strip ampere ratings limit.
- 1 Do not use appliance/voltage converters or kits sold for appliances with your Dell product.
- 1 To help protect your system components from sudden, transient increases and decreases in electrical power, use a surge suppressor, line conditioner, or uninterruptible power supply (UPS).

- 1 Position cables and power cords carefully; route cables and the power cord and plug so that they cannot be stepped on or tripped over. Be sure that nothing rests on your system components' cables or power cord.
- 1 Do not modify power cables or plugs. Consult a licensed electrician or your power company for site modifications. Always follow your local/national wiring rules.
- 1 To help avoid possible damage to the system board, wait 5 seconds after turning off the system before removing a component from the system board or disconnecting a peripheral device from the computer.
- 1 Handle batteries carefully. Do not disassemble, crush, puncture, short external contacts, dispose of in fire or water, or expose batteries to temperatures higher than 60 degrees Celsius (140 degrees Fahrenheit). Do not attempt to open or service batteries; replace batteries only with batteries designated for the product.
- 1 Turn down the volume before using headphones or other audio devices.

Precautions for Server and Storage Systems

Follow the additional safety guidelines for your system:

- 1 Unless your installation and/or troubleshooting documentation specifically allows it, do not remove enclosure covers, attempt to override the safety interlocks, or access any components inside the system. Depending on your system, installation and repairs may be done only by individuals who are qualified to service your computer or storage system equipment and trained to deal with products capable of producing hazardous energy levels.
- 1 When connecting or disconnecting power to hot-pluggable power supplies, if offered with your Dell product, observe the following guidelines:
 - o Install the power supply before connecting the power cable to the power supply.
 - o Unplug the power cable before removing the power supply.
 - o If the system has multiple sources of power, disconnect power from the system by unplugging *all* power cables from the power supplies.
- 1 Move products with care; ensure that all casters and/or stabilizers are firmly connected to the computer or storage system. Avoid sudden stops and uneven surfaces.

Precautions for Rack-Mountable Products

Observe the following precautions for rack stability and safety. Also refer to the rack installation documentation accompanying the system and the rack for specific warning and/or caution statements and procedures.

 **WARNING: Installing Dell system components in a Dell rack without the front and side stabilizers installed could cause the rack to tip over, potentially resulting in bodily injury under certain circumstances. Therefore, always install the stabilizers before installing components in the rack.**

After installing system components in a rack, never pull more than one component out of the rack on its slide assemblies at one time. The weight of more than one extended component could cause the rack to tip over and injure someone.

 **NOTE:** *Dell's server and storage systems are certified as components for use in Dell's rack cabinet using the Dell customer rack kit. The final installation of Dell systems and rack kits in any other brand of rack cabinet has not been approved by any safety agencies. It is the customer's responsibility to have the final combination of Dell systems and rack kits for use in other brands of rack cabinets evaluated for suitability by a certified safety agency.*

- 1 System rack kits are intended to be installed in a Dell rack by trained service technicians. If you install the kit in any other rack, be sure that the rack meets the specifications of a Dell rack.
- 1 Do not move large racks by yourself. Due to the height and weight of the rack, Dell recommends a minimum of two people to accomplish this task.
- 1 Before working on the rack, make sure that the stabilizers are secure to the rack, extend to the floor, and that the full weight of the rack rests on the floor. Install front and side stabilizers on a single rack or front stabilizers for joined multiple racks before working on the rack.
- 1 Always load the rack from the bottom up, and load the heaviest item in the rack first.
- 1 Make sure that the rack is level and stable before extending a component from the rack.
- 1 Extend only one component at a time from the rack.
- 1 Use caution when pressing the component rail release latches and sliding a component into or out of a rack; the slide rails can pinch your fingers.
- 1 After a component is inserted into the rack, carefully extend the rail into a locking position, and then slide the component into the rack.
- 1 Do not overload the AC supply branch circuit that provides power to the rack. The total rack load should not exceed 80 percent of the branch circuit rating.

- 1 Ensure that proper airflow is provided to components in the rack.
- 1 Do not step on or stand on any system/component when servicing other systems/components in a rack.

Precautions for Products With Modems, Telecommunications, or Local Area Network Options

Observe the following guidelines when working with options:

- 1 Do not connect or use a modem or telephone during a lightning storm. There may be a risk of electrical shock from lightning.
- 1 Never connect or use a modem or telephone in a wet environment.
- 1 Do not plug a modem or telephone cable into the network interface controller (NIC) receptacle.
- 1 Disconnect the modem cable before opening a product enclosure, touching or installing internal components, or touching an uninsulated modem cable or jack.
- 1 Do not use a telephone line to report a gas leak while you are in the vicinity of the leak.

Precautions for Products With Laser Devices

Observe the following precautions for laser devices:

- 1 Do not open any panels, operate controls, make adjustments, or perform procedures on a laser device other than those specified in the product's documentation.
- 1 Only authorized service technicians should repair laser devices.

When Working Inside Your Computer

Before you remove the computer covers, perform the following steps in the sequence indicated.

NOTICE: Some Dell systems can be serviced only by trained service technicians because of high voltages and energy hazards. Do not attempt to service the computer system yourself, except as explained in this guide and elsewhere in Dell documentation. Always follow installation and service instructions closely.

NOTICE: To help avoid possible damage to the system board, wait 5 seconds after turning off the system before removing a component from the system board or disconnecting a peripheral device from the computer.

1. Turn off your computer and any peripherals.
2. Ground yourself by touching an unpainted metal surface on the chassis, such as the metal around the card-slot openings at the back of the computer, before touching anything inside your computer.

While you work, periodically touch an unpainted metal surface on the computer chassis to dissipate any static electricity that might harm internal components.

3. Disconnect your computer and peripherals from their power sources. Also, disconnect any telephone or telecommunication lines from the computer.

Doing so reduces the potential for personal injury or shock.

In addition, take note of these safety guidelines when appropriate:

- 1 When you disconnect a cable, pull on its connector or on its strain-relief loop, not on the cable itself. Some cables have a connector with locking tabs; if you are disconnecting this type of cable, press in on the locking tabs before disconnecting the cable. As you pull connectors apart, keep them evenly aligned to avoid bending any connector pins. Also, before you connect a cable, make sure that both connectors are correctly oriented and aligned.
- 1 Handle components and cards with care. Don't touch the components or contacts on a card. Hold a card by its edges or by its metal mounting bracket. Hold a component such as a microprocessor chip by its edges, not by its pins.



CAUTION: There is a danger of a new battery exploding if it is incorrectly installed. Replace the battery only with the same or equivalent type recommended by the manufacturer. Discard used batteries according to the manufacturer's instructions.

Protecting Against Electrostatic Discharge

Static electricity can harm delicate components inside your computer. To prevent static damage, discharge static electricity from your body before you touch any of your computer's electronic components, such as the microprocessor. You can do so by touching an unpainted metal surface on the computer chassis.

As you continue to work inside the computer, periodically touch an unpainted metal surface to remove any static charge your body may have

accumulated.

You can also take the following steps to prevent damage from electrostatic discharge (ESD):

- 1 When unpacking a static-sensitive component from its shipping carton, do not remove the component from the antistatic packing material until you are ready to install the component in your computer. Just before unwrapping the antistatic packaging, be sure to discharge static electricity from your body.
- 1 When transporting a sensitive component, first place it in an antistatic container or packaging.
- 1 Handle all sensitive components in a static-safe area. If possible, use antistatic floor pads and workbench pads.

The following notice may appear throughout this document to remind you of these precautions:

NOTICE: See "Protecting Against Electrostatic Discharge" in the safety instructions at the front of this guide.

Ergonomic Computing Habits

⚠ CAUTION: Improper or prolonged keyboard use may result in injury.

⚠ CAUTION: Viewing the monitor screen for extended periods of time may result in eye strain.

For comfort and efficiency, observe the following ergonomic guidelines when you set up and use your computer system:

- 1 Position your system so that the monitor and keyboard are directly in front of you as you work. Special shelves are available (from Dell and other sources) to help you correctly position your keyboard.
- 1 Set the monitor at a comfortable viewing distance (usually 510 to 610 millimeters [20 to 24 inches] from your eyes).
- 1 Make sure that the monitor screen is at eye level or slightly lower when you sit in front of the monitor.
- 1 Adjust the tilt of the monitor, its contrast and brightness settings, and the lighting around you (such as overhead lights, desk lamps, and the curtains or blinds on nearby windows) to minimize reflections and glare on the monitor screen.
- 1 Use a chair that provides good lower back support.
- 1 Keep your forearms horizontal with your wrists in a neutral, comfortable position while you use the keyboard or mouse.
- 1 Always leave space to rest your hands while you use the keyboard or mouse.
- 1 Let your upper arms hang naturally at your sides.
- 1 Sit erect, with your feet resting on the floor and your thighs level.
- 1 When sitting, make sure the weight of your legs is on your feet and not on the front of your chair seat. Adjust your chair's height or use a footrest, if necessary, to maintain proper posture.
- 1 Vary your work activities. Try to organize your work so that you do not have to type for extended periods of time. When you stop typing, try to do things that use both hands.



- 1 Monitor screen at or below eye level
 - 2 Wrists relaxed and flat
 - 3 Arms at desk level
 - 4 Feet flat on the floor
 - 5 Monitor and keyboard positioned directly in front of user
-

[Back to Contents Page](#)

[Back to Contents Page](#)

Installing and Configuring SCSI Drivers: Dell™ PowerEdge™ 4400 Systems User's Guide

- [Overview](#)
 - [Installing SCSI Drivers for an Optional, Integrated RAID Controller in Windows NT 4.0](#)
 - [The SCSI.Select Utility](#)
 - [Driver Installation for Windows NT 4.0](#)
 - [Installation for Novell NetWare 4.2](#)
 - [Installation for Novell NetWare 5.0](#)
 - [Using SCSI Devices](#)
 - [Troubleshooting for Windows NT](#)
 - [Troubleshooting for Novell NetWare](#)
-

Overview

This section describes how to install and configure the Dell small computer system interface (SCSI) device drivers included with your Dell PowerEdge 4400 computer system. These device drivers are designed to work with the Adaptec AIC-7899 Ultra 160/m SCSI-3 controller and the Adaptec AIC-7880 Ultra/Narrow SCSI-3 controller (limited to narrow SCSI by implementation) on the system board.

Each channel of the AIC-7899 supports up to eight internal SCSI hard-disk drives via a SCSI backplane board or via external cabling. Up to eight hard-disk drives are supported in the PowerEdge 4400. The AIC-7880 supports up to three externally accessible SCSI devices in the system's external drive bays.

The AIC-7899, AIC-7880, and the optional AHA-2940U2W SCSI controller card are all part of the Adaptec 78xx series of SCSI controllers. The Adaptec SCSI basic input/output system (BIOS), which is stored in your computer system's flash memory or on the optional AHA-2940U2W SCSI controller card, links these SCSI device drivers to the AIC-7899 and AIC-7880 SCSI controller chips or the optional AHA-2940U2W SCSI controller card while booting or in the DOS environment.

If you are using an optional Dell PowerEdge Expandable RAID Controller (PERC), see "[Installing SCSI Drivers for an Optional, Integrated RAID Controller in Windows NT 4.0](#)" or your Dell PowerEdge Expandable RAID Controller documentation for information on installing your SCSI device drivers.

For instructions on installing SCSI hardware devices such as hard-disk drives, tape drives, or CD-ROM drives, trained service technicians should see "Installing Drives in the External Bays" and "Installing Drives in the Internal Bays" in the *Installation and Troubleshooting Guide*. After the SCSI devices are installed, install and configure any SCSI device drivers to enable them to communicate with your operating system.

SCSI device drivers are provided for the following operating systems:

- 1 Microsoft Windows NT® Server 4.0 operating system
- 1 Novell® NetWare® 4.2 and 5.0 operating systems

See "[Using the Dell OpenManage Server Assistant CD](#)" for instructions on creating a diskette of drivers for your operating system. For instructions on configuring the SCSI device drivers, see the following subsections.

Installing SCSI Drivers for an Optional, Integrated RAID Controller in Windows NT 4.0

To install SCSI drivers for the optional, integrated redundant arrays of independent disks (RAID) controller in Windows NT 4.0, perform the following steps:

1. Boot from the Microsoft Windows NT Server CD, and press <F6> when the first **Windows NT Setup** screen appears.

This action disables automatic detection of SCSI devices.

2. Load the RAID driver.

Press <s> to select the **Specify Additional Device** option. Insert the PERC driver diskette into drive A, and select **PowerEdge RAID II NT DRIVER** from the list of drivers.

3. Press <Enter> and continue with the setup.

The following list of SCSI device drivers appears:

```
Adaptec AHA-294X/AHA-394X/AIC-78XX SCSI Controller
PowerEdge RAID II NT DRIVER
```

The **readme.txt** files that are included with your SCSI device drivers (in the device driver `\pe4400\scsi` subdirectory on the CD) provide updates to the information in this guide.

Use the editor included with your operating system to view or print the **readme.txt** file or any other readme file.

The SCSISelect Utility

The BIOS for the integrated Adaptec AIC-7899 and AIC-7880 SCSI controllers includes the menu-driven SCSISelect configuration utility, which allows you to change SCSI controller settings without opening the computer. SCSISelect also contains SCSI disk utilities that let you low-level format or verify the disk media of your SCSI hard-disk drives.

SCSISelect Default Settings

Default settings for the integrated AIC-7880 SCSI controller are shown in [Table 1](#) and for the integrated AIC-7899 SCSI controller are shown in [Table 2](#). These default settings are appropriate for most Peripheral Component Interconnect (PCI) systems. Run SCSISelect only if you need to change any of the default settings.

 **NOTES:** To change the configuration settings, you must run the SCSISelect Utility twice—once for the AIC-7899 SCSI controller and once for the AIC-7880 SCSI controller.

The term **host adapter** is used throughout this file to refer to the integrated AIC-7899 and AIC-7880 SCSI controllers.

If the AIC-7899 controller card does not control the bootable hard-disk drive, you may want to disable its BIOS. Do not disable the BIOS for the AIC-7880 controller card, because the card controls the CD-ROM drive.

For situations in which you might want or need to change the settings, see the descriptions of each setting in the following subsections. To change any of the default settings or to format or verify a disk, see "[Starting the SCSISelect Utility.](#)"

Table 1. AIC-7880 SCSI Controller Settings

Setting	Default
SCSI Bus Interface Definitions:	
Host Adapter SCSI ID	7
SCSI Parity Checking	Enabled
Host Adapter SCSI Termination	Enabled
Boot Device Options:	
Boot Target ID	0
Boot LUN Number	0
SCSI Device/Configuration:	
Initiate Sync Negotiation	Yes (Enabled)
Maximum Sync Transfer Rate	20 MB/sec
Enable Disconnection	Yes (Enabled)
Advanced Host Adapter:	
Host Adapter BIOS	Enabled
Support Removable Disks Under BIOS As Fixed Disks	Boot Only
Extended BIOS Translation For DOS Drivers > 1 GB	Enabled
Display <Ctrl><a> Message During BIOS Initialization	Enabled
Multiple LUN Support	Disabled
BIOS Support For Bootable CD-ROM	Enabled
BIOS Support For Int 13 Extensions	Enabled
Support For Ultra SCSI Speed	Enabled

NOTE: For the full name of an abbreviation or acronym used in this table, see the "[Glossary.](#)"

Table 2. AIC-7899 SCSI Controller Settings

Setting	Default
SCSI Bus Interface Definitions:	
Host Adapter SCSI ID	7

SCSI Parity Checking	Enabled
Host Adapter SCSI Termination	Automatic
Boot Device Options:	
Boot Target ID	0
Boot LUN Number	0
SCSI Device/Configuration:	
Initiate Sync Negotiation	Yes (Enabled)
Maximum Sync Transfer Rate	160 MB/sec
Enable Disconnection	Yes (Enabled)
Initiate Wide Negotiation	Yes (Enabled)
Send Start Unit Command	Yes (Enabled)
BIOS Multiple LUN Support	No (Enabled)
Include in BIOS Scan	Yes (Enabled)
Advanced Host Adapter:	
Host Adapter BIOS	Enabled
Support Removable Disks Under BIOS As Fixed Disks	Boot Only
Plug and Play SCAM Support	Disabled
Reset SCSI Bus at IC Initialization	Enabled
Extended BIOS Translation For DOS Drivers > 1 GB	Enabled
Display <Ctrl><a> Message During BIOS Initialization	Enabled
BIOS Support For Bootable CD-ROM	Enabled
BIOS Support For Int 13 Extensions	Enabled
Support For Ultra SCSI Speed	Enabled

NOTE: For the full name of an abbreviation or acronym used in this table, see the ["Glossary."](#)

SCSI Bus Interface Definitions

The basic host adapter settings are the SCSI*Select* settings most likely to require modification:

- 1 **Host Adapter SCSI ID** — Sets the host adapter's SCSI ID. The default setting is **SCSI ID 7**, which allows the host adapter to support narrow SCSI devices in addition to wide SCSI devices. Dell recommends that you leave the host adapter set to **SCSI ID 7**.
- 1 **SCSI Parity Checking** — Determines whether the host adapter verifies the accuracy of data transfer on the SCSI bus. The default setting is **Enabled**. You should disable **SCSI Parity Checking** if any SCSI device connected to the host adapter does not support SCSI parity; otherwise, leave it enabled. Most SCSI devices support SCSI parity. If you are unsure if a device supports SCSI parity, consult the documentation for the device.
- 1 **Host Adapter SCSI Termination** — Sets termination on the host adapter. The default setting for the Adaptec AIC-7880 host adapters is **Enabled**; the default setting for the AIC-7899 host adapter is **Automatic**. Dell recommends that you leave this option set to the default.

Boot Device Options

The boot device options allow you to specify the device from which to boot your computer:

- 1 **Boot Target ID** — Specifies the SCSI ID of the device from which you want to boot your system. SCSI IDs are set for the hard-disk drive according to the drive's location on the backplane board. The default setting for **Boot Target ID** is **SCSI ID 0**.
- 1 **Boot LUN Number** — Allows you to specify a particular logical unit number (LUN) from which to boot your boot device if your boot device has multiple LUNs and **Multiple LUN Support** is enabled (see "[Advanced Host Adapter Settings](#)"). The default setting is **LUN 0**.

SCSI Device/Configuration Settings

The SCSI device/configuration settings allow you to configure certain parameters for each device on the SCSI bus. To configure a specific device, you must know the SCSI ID assigned to that device. If you are not sure of the SCSI ID, see "[Using the SCSI Disk Utilities](#)."

- 1 **Initiate Sync Negotiation** — Determines whether the host adapter initiates synchronous data transfer negotiation (synchronous negotiation) between itself and the device. The default setting is **Yes**.

Synchronous negotiation is a SCSI feature that allows the host adapter and its attached SCSI devices to transfer data in synchronous

mode. Synchronous data transfer is faster than asynchronous data transfer.

The host adapter always responds to synchronous negotiation if the SCSI device initiates it. If neither the host adapter nor the SCSI device initiates synchronous negotiation, data is transferred asynchronously.

Normally, you should leave the **Initiate Sync Negotiation** setting enabled, because most SCSI devices support synchronous negotiation and because it allows for faster data transfer.

 **NOTE:** Some older SCSI-1 devices do not support synchronous negotiation. This may cause your computer to operate erratically or hang if **Initiate Sync Negotiation** is set to **Yes**. Set **Initiate Sync Negotiation** to **No** for these devices.

- 1 **Maximum Sync Transfer Rate** — Sets the maximum synchronous data transfer rate that the host adapter supports. The AHA-7899 host adapter supports rates up to 160 megabytes per second (MB/sec), and the AHA-7880 host adapter supports rates up to 40 MB/sec. The default setting for the AHA-7899 is **160 MB/sec** (its maximum). The default setting for the AHA-7880 is **20 MB/sec**.

If the host adapter is set to not negotiate for synchronous data transfer, the maximum synchronous transfer rate is the maximum rate that the host adapter accepts from the device during negotiation. (This is standard SCSI protocol.)

- 1 **Enable Disconnection** (sometimes called disconnect/reconnect) — Determines whether the host adapter allows the SCSI device to disconnect from the SCSI bus. Enabling disconnection allows the host adapter to perform other operations on the SCSI bus while the SCSI device is temporarily disconnected. The default setting is **Yes**.

Leave **Enable Disconnection** set to **Yes** if two or more SCSI devices are connected to the host adapter. This optimizes SCSI bus performance. If only one SCSI device is connected to the host adapter, set **Enable Disconnection** to **No** to achieve slightly better performance.

- 1 **Initiate Wide Negotiation** — Determines whether the host adapter attempts 16-bit data transfer instead of 8-bit data transfer. The default setting is **Yes**.

 **NOTE:** Some 8-bit SCSI devices may have trouble handling wide negotiation, which may result in erratic behavior or a hang condition. For these devices, set **Initiate Wide Negotiation** to **No**.

When this option is set to **Yes**, the host adapter attempts 16-bit transfer. When this option is set to **No**, 8-bit data transfer is used unless the SCSI device itself requests wide negotiation. The effective transfer rate is doubled when 16-bit data transfer is used because the data path for wide SCSI is twice the size of normal 8-bit SCSI.

- 1 **Send Start Unit Command** — Determines whether the start unit command is sent to the SCSI device during the boot routine. The default setting is **Yes**.

Setting this option to **Yes** reduces the load on your computer's power supply by allowing the host adapter to start SCSI devices one at a time when you boot your computer. When this option is set to **No**, the devices are allowed to start at the same time. Most devices require you to set a jumper before they can respond to this command.

 **NOTE:** For many devices, if **Send Start Unit Command** is set to **Yes**, the boot routine time will vary depending on how long it takes each drive to start.

- 1 **BIOS Multiple LUN Support** — Provides support for peripherals that contain multiple SCSI devices, such as autoloading tape drives and CD-ROM changers.
- 1 **Include in BIOS Scan** — Enables you to set whether the system BIOS scans this device during system start-up. The default setting is **Yes**.

Advanced Host Adapter Settings

The advanced host adapter settings should not be changed unless absolutely necessary. These values are set by Dell, and changing them may cause conflicts with the SCSI devices.

- 1 **Host Adapter BIOS** — Enables or disables the host adapter BIOS. The default setting is **Enabled**.

 **NOTE:** Several SCSISelect options are not valid unless the host adapter BIOS is enabled.

If you are booting from a SCSI hard-disk drive connected to the host adapter, the BIOS must be enabled. You should disable the host adapter BIOS if the peripherals on the SCSI bus (for example, CD-ROM drives) are all controlled by device drivers and do not need the BIOS.

- 1 **Support Removable Disks Under BIOS As Fixed Disks** — Controls which removable-media drives are supported by the host adapter BIOS. The default setting is **Boot Only**. The following choices are available.

NOTICE: If a removable-media SCSI device is controlled by the host adapter BIOS, do not remove the media while the drive is on or you may lose data. If you want to be able to remove media while the drive is on, install your removable-media device driver and set this option to **Disabled**.

- 1 **Boot Only** — Only the removable-media drive designated as the boot device is treated as a hard-disk drive.

- 1 **All Disks** — All removable-media drives supported by the BIOS are treated as hard-disk drives.
- 1 **Disabled** — No removable-media drives are treated as hard-disk drives. In this situation, software drivers are needed because the drives are not controlled by the BIOS.
- 1 **Plug and Play SCAM Support** — Provides automatic configuration of SCSI devices in operating systems that support Plug and Play. Dell recommends that you leave this option set to **Disabled**.
- 1 **Reset SCSI Bus at IC Initialization** — Enables the SCSI bus to be reset when the controller is initialized. The default setting is **Enabled**.
- 1 **Extended BIOS Translation For DOS Drives > 1 GB** — Determines whether extended translation is available for SCSI hard-disk drives with capacities greater than 1 gigabyte (GB). The default setting is **Enabled**.

NOTICE: Back up your hard-disk drive before you change the translation scheme. All data is erased when you change from one translation scheme to another.

The standard translation scheme for SCSI host adapters provides a maximum accessible capacity of 1 GB. To support hard-disk drives larger than 1 GB, the 78xx series host adapters include an extended translation scheme that supports hard-disk drives as large as 8 GB, with a maximum partition size of 2 GB under the DOS operating system.

It is not necessary to enable the **Extended BIOS Translation** setting if you are using another operating system, such as Novell NetWare.

When you partition a hard-disk drive larger than 1 GB, use the DOS **fdisk** utility as you normally would. Because the cylinder size increases to 8 MB under extended translation, the partition size you choose must be a multiple of 8 MB. If you request a size that is not a multiple of 8 MB, **fdisk** rounds up to the nearest whole multiple of 8 MB.

- 1 **Display <Ctrl><a> Message During BIOS Initialization** — Determines whether the `Press <CTRL><A> for SCSISelect (TM) Utility!` message appears on your screen during system start-up. The default setting is **Enabled**. If this setting is disabled, you can still run the `SCSISelect` utility by pressing `<Ctrl><a>` after the host adapter BIOS banner appears.
- 1 **Multiple LUN Support** — Determines whether your system supports booting from a SCSI device that has multiple LUNs. The default setting is **Disabled**. Enable this option if your boot device has multiple LUNs.
- 1 **BIOS Support For Bootable CD-ROM** — Determines whether the host adapter BIOS provides support for booting from a CD-ROM drive. The default setting is **Enabled**.
- 1 **BIOS Support For Int 13 Extensions** — Determines whether the host adapter BIOS supports disks with more than 1024 cylinders. The default setting is **Enabled**.
- 1 **Support For Ultra SCSI Speed** — Determines whether the host adapter supports the fast transfer rates (20–40 MB/sec). The default setting is **Enabled**.

Starting the SCSISelect Utility

You can start the `SCSISelect` utility by pressing `<Ctrl><a>` when the following prompt appears briefly during start-up:

```
Press <CTRL><A> for SCSISelect (TM) Utility!
```

The first menu displays the **Configure/View Host Adapter Settings** and **SCSI Disk Utilities** options.

Using SCSISelect Menus

`SCSISelect` uses menus to list options that you can select. To select an option, press the up- and down-arrow keys to move the cursor to the option; then press `<Enter>`.

In some cases, selecting an option displays another menu. You can return to the previous menu at any time by pressing `<Esc>`. To restore the original `SCSISelect` default values, press `<F6>`.

Using the SCSI Disk Utilities

To access the SCSI disk utilities, select **SCSI Disk Utilities** from the menu that appears when you start `SCSISelect`. When the option is selected, `SCSISelect` immediately scans the SCSI bus (to determine the devices installed) and displays a list of all SCSI IDs and the device assigned to each ID.

When you select a specific ID and device, a menu appears, displaying the **Format Disk** and **Verify Disk Media** options.

NOTICE: The Format Disk option destroys all data on the hard-disk drive.

- 1 **Format Disk** — Runs a utility that allows you to perform a low-level format on a hard-disk drive. Most SCSI disk drives are formatted at the factory and do not need to be formatted again. The Adaptec Format Disk utility is compatible with the majority of SCSI disk drives.
- 1 **Verify Disk Media** — Runs a utility that allows you to scan the media of a hard-disk drive for defects. If the utility finds bad blocks on the media, it prompts you to reassign them; if you select **Yes**, those blocks are no longer used. You can press `<Esc>` at any time to exit the utility.

Exiting SCSISelect

To exit *SCSISelect*, press <Esc> until a message prompts you to exit. (If you changed any 78xx series host adapter settings, you are prompted to save the changes before you exit.) At the prompt, select **Yes** to exit, and then press any key to reboot the computer. Any changes that you made in *SCSISelect* take effect after the computer boots. (You can select **No** at the prompt if you are not ready to exit *SCSISelect*.)

Driver Installation for Windows NT 4.0

This section provides the following information about installing the Dell SCSI drivers for the Microsoft Windows NT 4.0 operating system:

- 1 Installing and/or updating the SCSI drivers for Windows NT
- 1 Removing a host adapter
- 1 Swapping a host adapter
- 1 Restoring a configuration if Windows NT fails to boot

Installation Overview

This section provides the information that you need to install and use the Dell SCSI drivers for the 78xx series of SCSI controllers with Windows NT.

The Windows NT 4.0 driver diskette that you create for the Microsoft Windows NT Server operating system contains the files that you need for driver installation. The **scsi** subdirectory on the diskette contains the following files to be used with Windows NT:

- 1 **adpu160m.sys** — Adaptec's 7899 Ultra 160/m driver for Windows NT
- 1 **aic78xx.sys** — Adaptec's 78xx series driver for Windows NT
- 1 **oemsetup.inf** — A file used by Windows NT Setup for driver installation
- 1 **readme.txt** — A text file describing the Adaptec 78xx driver for Windows NT

If you are installing Windows NT for the first time, see "[Installing Windows NT and the Driver for the First Time](#)" to begin driver installation. If Windows NT is already installed in your system, see "[Using Windows NT to Install or Update the Driver](#)."

Installing Windows NT and the Driver for the First Time

Windows NT 4.0 has SCSI drivers for the Adaptec 78xx series of SCSI controllers integrated into the operating system. When you load the operating system software, the drivers are automatically loaded. However, Dell recommends that you update the **aic78xx.sys** driver by using the diskette of drivers that you created from the *Dell OpenManage Server Assistant* CD. To install or update the **aic78xx.sys** driver for Windows NT 4.0, see the next subsection.

Using Windows NT to Install or Update the Driver

This section describes how to install or update the **aic78xx.sys** driver if Windows NT is already installed. If you are installing Windows NT for the first time, see "[Installing Windows NT and the Driver for the First Time](#)."

Perform the following steps only if Windows NT 4.0 is already installed:

1. Click the **Start** button, point to **Settings**, and click **Control Panel**.
2. Double-click the **SCSI Adapters** icon.
3. Click the **Driver** tab and then click **Add**.
4. Click **Have Disk**.
5. Insert the Windows NT 4.0 driver diskette that you created into drive A.
6. In the **Copy Manufacturer's Files From:** field, type `a:\scsi\` and click **OK**.
7. Select **Adaptec AHA-294x/AHA-394x/AHA4944** or **78xx PCI SCSI Controller (NT 4.0)**. Then click **OK**.
8. If the following message appears, click **New** to replace the existing driver:

The driver(s) for this SCSI Adapter are already on the system. Do you want to use the currently installed driver(s) or install new one(s).

9. If the following message appears, type `a:\scsi` in the dialog box and click **Continue**:

Please enter the full path to Adaptec's installation files.

These files are located in the **lscsi** directory on the Windows NT 4.0 Driver diskette.

The driver is copied from the diskette to your system.

10. Click **Yes** when prompted to restart the system and remove the diskette from drive A.

After the system reboots, the new driver is active. Some drive letter assignments may have changed from the previous configuration.

If you need additional assistance, see "[Troubleshooting for Windows NT.](#)"

Installation for Novell NetWare 4.2

This section provides the following information about installing and updating the Dell SCSI drivers for Novell NetWare 4.2:

- 1 Automatic driver loading using **startup.ncf** and **autoexec.ncf**
- 1 Booting a NetWare server from a SCSI drive, formatting media, and using removable media
- 1 Troubleshooting error messages generated during initialization

Installation Overview

This subsection provides the information that you need to install and use the Dell SCSI drivers for Novell NetWare 4.2. The Dell SCSI drivers for NetWare support the optional Adaptec AHA-2940U2W, the Adaptec AIC-7899 and AIC-7880 SCSI controllers.

Before you begin installation of the SCSI drivers for NetWare, you must create a diskette of drivers for NetWare 4.2. "[Using the Dell OpenManage Server Assistant CD](#)" provides instructions for creating these diskettes.

The Dell SCSI drivers for NetWare are fully tested and approved for NetWare. The NetWare **scsi** subdirectory on the NetWare 4.2 drivers diskette that you create contains files to be used with NetWare 4.2. The files appear in the **scsi** subdirectory on the NetWare driver diskette.

 **NOTE:** Your system must have a bootable version of DOS installed before you can complete the Novell NetWare installation.

Installing NetWare 4.2

This section describes how to install the system SCSI drivers at the same time you install NetWare 4.2. If NetWare 4.2 is already installed and you want to install or update the **adpu160.ham** and **aha2940.ham** drivers, refer to the NetWare *User's Guide* for installation instructions. Also, refer to the NetWare *User's Guide* for information about partitioning, creating a server name, and checking the Internetwork Packet eXchange (IPX) network number.

Before beginning, prepare your system with the Dell intraNetWare support diskette. Perform the following steps only if you are upgrading to NetWare 4.2 or installing it for the first time:

1. Make backup copies of all NetWare diskettes and use those backup copies as your working diskettes.
2. Boot the system to a DOS prompt.
3. Change to the CD-ROM drive prompt.

The installation files are located in the root directory on the CD.

4. Type `install` and press <Enter>.
5. Select a language at the language selection screen and press <Enter>.
6. Select whether you want to perform a simple or custom installation and press <Enter>.

If you select a simple installation, you can press <F1> to view the default settings for the installation.

7. If you are prompted to install NetWare symmetrical multiprocessing (SMP), select **No**.

Even if you plan to install NetWare SMP, select **No** at this screen. The intraNetWare Support Pack 4 or later must be applied before NetWare SMP can be installed. The system now searches for existing device drivers and hardware.

8. Press <F3> to continue through the next few screens.
9. When a screen appears asking you to select a disk driver, press <Ins>.
10. Insert the backup copy of the NetWare 4.2 driver diskette that you created in step 1 into the diskette drive.

If you have not already created this diskette, see "[Using the Dell OpenManage Server Assistant CD](#)" for instructions.

11. Press <F3>, and type the path to the **adpu160.ham** driver for NetWare (for example, `a:\scsi`).

12. Select the **adpu160.ham** driver and press <Enter>.

The system prompts you for a slot number for the device.

 **NOTE:** Specific help text for each driver appears in the middle of the screen as you scroll down the list. The **Loaded Drivers** window below the list of available drivers displays the names of drivers that are loaded and operational. For a new installation, this list is initially empty. For a selective installation, the list shows the drivers already running.

13. Press <Alt><Esc> to switch to the console prompt, type `load a:\scsi\adpu160.ham`, and press <Enter>.

A list of slot numbers is displayed separated by commas. Write down all slot numbers that are listed and press <Esc> to clear the command line. Press <Alt><Esc> to return to the installation screen.

14. Enter the slot number for the driver and press <Enter>.
15. Press <Enter> to save the parameters and continue.
16. When you are prompted to select an additional disk driver, select **Yes**.
17. Repeat steps 13 through 17 for each driver as necessary.
18. Select **Continue the Installation** to create disk partitions and system volumes and to specify volume names following the procedures listed in the NetWare *User's Guide*.
19. To load the driver automatically at server start-up, make sure the **startup.ncf** file includes the **load** command line and correct slot number for your host adapter. Refer to the NetWare *User's Guide* for information about editing the **startup.ncf** file.

Installation for NetWare 5.0

This section provides information on installing the SCSI drivers for the Novell NetWare 5.0 operating system. Instructions assume that NetWare 5.0 is installed and operational.

Creating the NetWare 5.0 SCSI Driver Diskette

If you have not already done so, use the *Dell OpenManage Server Assistant* CD to create a NetWare 5.0 SCSI driver diskette. See "[Using the Dell OpenManage Server Assistant CD](#)" for instructions on creating the diskette.

Uninstalling a SCSI Driver

If you are replacing an existing driver (for example, because it has become corrupted or an upgrade has become available), you must first remove the installed driver. To remove a driver, perform the following steps:

1. At the initial NetWare screen, press <Alt><Esc> to display the NetWare console screen.
2. At the server prompt, type `nwconfig` and press <Enter>.

The **NetWare Configuration** screen appears, displaying the **Configuration Options** menu.

3. At the **Configuration Options** menu, highlight **Driver Options** and press <Enter>.
4. At the **Driver Options** menu, highlight **Configure disk and storage device drivers** and press <Enter>.
5. At the **Additional Driver Actions** menu, highlight **Unload an additional driver** and press <Enter>.
6. At the **Selected Disk Drivers** menu, highlight the driver that you want to uninstall and press <Enter>.
7. At the message `Driver xxx successfully unloaded`, press <Enter>.

The **Additional Driver Actions** menu appears.

From the **Additional Driver Actions** menu, you can repeat steps 5 through 7 to uninstall an additional driver, start with step 5 of the next procedure to install a driver, or press <Esc> to exit.

Installing the SCSI Drivers for NetWare 5.0

To install NetWare 5.0 SCSI drivers from the NetWare 5.0 SCSI driver diskette that you created, perform the following steps:

1. At the initial NetWare screen, press <Alt><Esc> to display the NetWare console screen.
2. At the server prompt, type `nwconfig` and press <Enter>.

The **NetWare Configuration** screen appears, displaying the **Configuration Options** menu.

3. At the **Configuration Options** menu, highlight **Driver Options** and press <Enter>.

4. At the **Driver Options** menu, highlight **Configure disk and storage device drivers** and press <Enter>.
5. At the **Additional Driver Actions** menu, highlight **Load an additional driver** and press <Enter>.
The software scans the system to determine what drivers are already installed.
6. When the **Select a driver** menu appears, insert the NetWare 5.0 SCSI driver diskette into the diskette drive and press <Insert> to install an unlisted driver.
7. Read the instructions on the screen and press <Enter> to continue.
8. At the **Select a driver to install** menu, highlight a desired driver and press <Enter>.
9. When you are prompted to confirm, highlight **Yes** and press <Enter>.
10. To accept the default server boot path that is displayed, press <Enter>.
The software copies the driver to the selected location.
11. At the **Driver xxx Parameter Actions** screen, highlight **Select/Modify driver parameters** and press <Enter>.
12. At the **driver parameters** screen, type 1 for the integrated SCSI adapter or enter the slot number of the SCSI adapter card.
 *NOTE: The integrated SCSI adapter is always assigned to slot 1. If an adapter card is installed in slot 1, you must specify it as being in slot 2. An adapter card installed in slot 2 or a higher numbered slot is assigned its true physical slot number.*
13. Press <F10> to save the parameters and exit.
14. At the **Driver xxx Parameter Actions** screen, highlight **Save parameter and load driver** and press <Enter>.
15. At the **NetWare Configuration** screen, confirm that the new driver has been added to the list that is displayed.
16. Repeat steps 3 through 15 for any additional drivers you want to install.
17. Press <Esc> three times. At the **Exit nwconfig?** dialog box, highlight **Yes** and press <Enter>.

If you need additional assistance, see "[Troubleshooting for NetWare.](#)"

Using SCSI Devices

The subsections that follow provide procedures and tips on the following topics:

- 1 Formatting media
- 1 Using removable media
- 1 Verifying status
- 1 Using drives that are tested and approved for NetWare
- 1 Using the NetWare tape backup utility
- 1 Setting up a CD-ROM drive with NetWare 4.2

Formatting Media

NetWare's **nwconfig.nlm** program lets you optionally format a hard-disk drive for use with NetWare. If you are using SCSI drives, the program allows you to low-level format several SCSI drives simultaneously. The NetWare format procedure is not the same as using **fdisk** or **format** under DOS.

NOTICE: You should not use NetWare to format a hard-disk drive that contains partitions for other operating systems because that information may be destroyed.

Using Removable Media

The **adpu160.ham** driver module fully supports removable-media disk drives, including magneto-optical drives. Removable media is treated as a standard SCSI hard-disk drive, with some exceptions:

- 1 The driver only recognizes and registers media with 512 bytes per sector.
- 1 NetWare allows you to mount or dismount the media and lock or unlock the media.

These removable media options are supported by NetWare's **monitor.nlm** program.

To set up the removable media, perform the following steps:

1. Load **monitor.nlm** to display the various options.

2. Select **Disk Information**.

All system hard-disk drives appear.

3. Select the removable-media device.

Drive status options appear as shown in Table 3.

Table 3. Drive Status Options

Menu Option	Default Value
Volume Segments on Drive ¹	Select for a list
Read After Write Verify ¹	Hardware Level
Drive Light Status ¹	Not supported
Driver Operating Status ¹	Active
Removable Drive Mount Status ²	Mounted
Removable Drive Lock Status ²	Not Locked

¹ Valid for both removable and nonremovable SCSI drives.

² Valid for removable media only.

Verify Status

The **Read After Write Verify** option is set to **Hardware Level** by default. This option cannot be specified in the **startup.ncf** or **autoexec.ncf** file. However, the default can be set on the command line. Refer to the NetWare *User's Guide* for information about using the **load** command-line options.

The available options are defined in Table 4.

Table 4. Read After Write Verify Options

Option Setting	Function
Disabled	All writes to SCSI disk drives are executed with the SCSI Write command (0Ah or 2Ah).
Hardware Level	All writes to SCSI disk drives are executed with the SCSI Write and Verify command (2Eh) or (if this command is not supported by the drive) with the SCSI Write command (0Ah or 2Ah), followed by the SCSI Verify command (2Fh).
Software Level	Not supported.

Mount Status

Mounting causes a drive to come online as a NetWare storage device. Dismounted drives are inactive and cannot be accessed.

Before you eject the current media, dismount it. When the mount status is **Dismounted**, eject the media. However, NetWare does not allow you to dismount media that are locked.

To insert your new media, wait for the drive to spin up, and then select the **Removable Drive Mount Status** option.

Lock Status

If your removable-media device supports the lock/unlock feature, you can lock the media. The media must be in the **Not Locked** state before you can eject it.

Using Drives Tested and Approved for NetWare

To be fully certified as NetWare "Yes, Tested and Approved," a drive and host adapter must both pass a qualification process that takes place before you see the product. The goals of NetWare testing are to simplify installation and provide the highest quality disk subsystem.

Adaptec 78xx series host adapters and their drivers are fully tested and approved for NetWare. This means that you can purchase a NetWare drive (certified as "Yes, Tested and Approved") from a vendor, connect it to your computer system or host adapter, partition it, and create a volume without any compatibility concerns.

 *NOTE: Dell recommends using only Dell-tested drives.*

Adaptec's **adpu160.ham** driver module is flexible enough to allow you to connect SCSI drives that are tested and approved for NetWare as well as standard SCSI drives to a single host adapter. The driver registers each hard-disk drive accordingly.

Drive registration is a user-transparent process; no user interaction is required. You can tell that the drive has been detected as NetWare-tested and NetWare-approved if the message `NetWare Yes Tested and Approved` is included in the drive description string that appears when you run **monitor.nlm** (disk options).

Using the NetWare Tape Backup Utility

Included with NetWare is a server-based tape backup utility called **sbackup.nlm**. This allows backup of server disk drives to a server tape drive. The **sbackup.nlm** utility supports Adaptec host adapters. To load the backup utility, perform the following steps:

1. Load the SCSI adapter driver by entering:
`load [pathname]\adpu160.ham [options] slot=x`
The ASPI layer (**aspitran.dsk**) is automatically loaded.
2. Refer to the Novell NetWare documentation for additional instructions on loading the server backup software. Refer to the *NetWare Server Backup User's Guide* to load the **tsa** and **sbackup** modules.

Setting Up a CD-ROM Drive With NetWare 4.2

To use a CD-ROM drive with NetWare 4.2, perform the following steps:

1. Ensure that the CD-ROM driver for NetWare 4.2 (**aha2940.ham**) is loaded. If necessary, load the driver by entering the following command line:
`load [pathname]\aha2940.ham slot=x`
2. Load **cdrom.nlm** by entering the following command line:
`load [pathname]\cdrom.nlm`
3. Enter the following line at the prompt and then note the number and name of the CD that appears:
`cd device list`
4. Enter the number or volume name of the CD at the command line:
`cd mount [number]`
or
`cd mount [name]`

The CD-ROM drive is now ready to be accessed as a volume.

Troubleshooting for Windows NT

The boot manager for Windows NT contains recovery logic to allow you to return to the last known good configuration. If you have changed your host adapter configuration and Windows NT no longer boots, perform the following steps to recover it:

1. Undo any hardware changes that you have made to the computer since it was last operational.
2. Reboot the computer. Watch the display carefully during start-up. If the following message appears, press the spacebar, type <1> at the next screen, and then follow the instructions on the screen to continue booting with the last known good configuration:

```
Press spacebar NOW to invoke the Last Known Good menu
```

3. When your computer is operational again, check all of the hardware and software configuration changes that you want to make. Look specifically for conflicts with parts of the existing system configuration that are not being changed.

If you cannot determine the source of the error, contact Dell for assistance. See "Getting Help" in the *Installation and Troubleshooting Guide* for instructions on contacting Dell for technical assistance.

Troubleshooting for NetWare

Any error that occurs while the driver is initializing prevents it from loading. If an error does occur, the driver causes the computer to beep and then display the following numbered error message:

```
xxx message
```

The `xxx` indicates the error code, and `message` is a descriptive line describing the error. The error codes are divided into three categories:

- 1 000-099 — Non-host-adapter specific

| 100-299 — Host-adapter specific

| 300-999 — Reserved

Specific error codes, such as those in the following subsections, appear only if you have installed the host adapters and drivers that generate them.

Non-Host-Adapter Specific Error Codes

The following error codes alert you to error conditions caused by factors not related to the host adapter:

000 Failed ParseDriverParameters call

A call to NetWare's ParseDriverParameters routine has failed for some unknown reason. The command line contains errors, or you pressed <Esc> at the port or slot prompt.

001 Unable to reserve hardware, possible conflict

The driver failed in its attempt to reserve the host adapter's hardware settings (that is, direct memory access [DMA] and interrupt request [IRQ] settings). Another card in your system may be causing a conflict with the host adapter.

002 NetWare rejected card Failed AddDiskSystem call

The driver failed in its attempt to register the host adapter with NetWare. The file server may not have enough memory.

003 Invalid command line option entered > option

An invalid option was entered on the command line. The invalid option that was entered is also displayed.

004 Invalid command line, please enter correctly

The driver was unable to understand the command line options that you entered. Be sure that you have entered these options correctly.

Host-Adapter Specific Error Codes

The following error codes alert you to error conditions caused by factors related to the host adapter:

200 No host adapter found for this driver to register

No Adaptec 78xx host adapter was found in your computer for the driver to register. Be sure that the host adapter is properly configured and properly seated in the slot.

203 Invalid 'device' setting

You have entered an invalid slot setting on the command line. You can only enter slot numbers for valid host adapters. If you load without the slot option, you will be prompted to enter a valid value.

204 Invalid 'verbose' setting, use 'y'

You can only enter *y* for this option (verbose=*y*).

205 Invalid 'removable' setting, use 'off'

You can only enter *off* for this option (removable=*off*).

206 Invalid 'fixed_disk' setting, use 'off'

You can only enter *off* for this option (fixed_disk=*off*).

208 SCSI present but not enabled/configured for PCI

A host adapter is present, but its bus or device entry has not been enabled.

[Back to Contents Page](#)

[Back to Contents Page](#)

Using the System Setup Program: Dell™ PowerEdge™ 4400 Systems User's Guide

[Overview](#)

[Using the System Password Feature](#)

[Entering the System Setup Program](#)

[Using the Setup Password Feature](#)

[System Setup Screens](#)

[Disabling a Forgotten Password](#)

[System Setup Options](#)

[Responding to Error Messages](#)

Overview

Each time you turn on your computer system, the system compares the hardware installed in the system to the hardware listed in the system configuration information stored in nonvolatile random-access memory (NVRAM) on the system board. If the system detects a discrepancy, it generates error messages that identify the incorrect configuration settings. The system then prompts you to enter the System Setup program to correct the setting.

You can use the System Setup program as follows:

- 1 To change the system configuration information after you add, change, or remove any hardware in your system
- 1 To set or change user-selectable options—for example, the time or date on your system
- 1 To enable or disable all integrated devices in your system

NOTICE: Whenever you make changes to the System Setup program or change settings for built-in devices, you must run the Resource Configuration Utility, make any necessary changes, and save the system configuration information. Failure to do so may cause resource conflicts between Peripheral Component Interconnect (PCI) devices (such as PCI expansion cards, the integrated video controller, or the integrated small computer system interface [SCSI] host adapter). See "[Configuring Expansion Cards](#)" for more information about how PCI devices are configured based on settings in the Resource Configuration Utility.

You can view the current settings at any time. When you change a setting, the system reboots automatically so that the change can take effect.

After you set up your system, run the System Setup program to familiarize yourself with your system configuration information and optional settings. Dell recommends that you print the System Setup screens (by pressing the <Print Screen> key) or record the information for future reference.

Before you use the System Setup program, you need to know the kind of diskette drive(s) and hard-disk drive(s) installed in your computer. If you are unsure of any of this information, see the Manufacturing Test Report that was shipped with your system. You can access the **Manufacturing Test Report** in the **Dell Accessories** folder.

Entering the System Setup Program

Enter the System Setup program as follows:

1. Turn on your system.
If your system is already on, shut it down and then turn it on again.
2. Press <F2> immediately after you see the following message:

Press <F2> for System Setup

If you wait too long and your operating system begins to load into memory, let the system complete the load operation; then shut down the system and try again.

 **NOTE:** To ensure an orderly system shutdown, consult the documentation that accompanied your operating system.

You can also enter the System Setup program by responding to certain error messages. See "[Responding to Error Messages](#)."

System Setup Screens

The three System Setup screens, **Page 1**, **Page 2**, and the **Device List** screen, display the current setup and configuration information and optional settings for your system. (Typical examples are illustrated in [Figure 1](#).) Information on the System Setup screens is organized in five boxed areas:

- 1 Title box — The box at the top of both screens lists the system name, page number, and the revision number of the basic input/output system (BIOS).

- 1 Configuration options — The box on the left half of both screens lists the options that define the installed hardware in your computer. Fields beside the options contain settings or values; those that appear bright on the screen can be changed. Settings or values that you cannot change because they are determined by the system appear less bright. Some options have multiple fields, which may show settings or values as bright or less bright depending upon what settings or values you entered in other fields.
- 1 Help — The box on the upper-right half of both screens displays help information for the option with a currently highlighted field.
- 1 System data — The box in the lower-right corner of both screens displays information about your system.
- 1 Key functions — The line of boxes across the bottom of both screens lists keys and their functions within the System Setup program.

Using the System Setup Program

Table 1 lists the keys that you use to view or change information on the System Setup screens and to exit the program.

Table 1. System-Setup Navigation Keys















Keys	Action
 or 	Moves to the next field.
  or 	Moves to the previous field.
 or 	Cycles through the settings in a field. In many fields, you can also type the appropriate value.
 or 	Scrolls through help information.
 or 	Switches between Page 1 and Page 2.
	Exits the System Setup program and reboots the system if any changes were made. For most of the options, any changes you make are recorded but do not take effect until the next time you boot the system. For a few options (as noted in the help area), the changes take effect immediately.
 	Exits the System Setup program and reboots the system, implementing any changes you have made.

Figure 1. System Setup Screens

Dell Computer Corporation (www.dell.com)	
Page 1 of 2	System PowerEdge 4400/600 Setup BIOS Version: XXX
Time: 22:46:58 Date: Thurs June 10, 1999 Diskette Drive A: 3.5 inch, 1.44 MB Diskette Drive B: Not Installed Speaker: On Num Lock: None OS Install Mode: Off Fan Speed: Full Speed System Alert: Fault Processor Serial Number: Disabled Processor Core: 600 MHz Processor Bus: 133 MHz Processor 1: CO Processor 2: Not Installed	This category sets the time in 24-hour format (hours:minutes:seconds) for the internal clock/calendar. To change the value in a field, enter a number or use the left- or right-arrow key. Changes take effect immediately. Pentium® III Xeon™ Processor Level 2 Cache: 256 KB Advanced System Memory: 128 MB ECC SDRAM Video Memory: 4 MB SDRAM Service Tag:
Tab, Shift-Tab change fields ←, → change values Alt-P next Esc exit Alt-B reboot	

Dell Computer Corporation (www.dell.com)	
Page 2 of 2	System PowerEdge 4400/600 Setup BIOS Version: XXX
Keyboard Errors: Report Boot Sequence: Device List, Ctrl → System Password: Disabled by Jumper Setup Password: Disabled by Jumper Password Status: Unlocked ———— Integrated Devices ———— USB: On Mouse: On Serial Port 1: Auto Serial Port 2: Auto Parallel Port: 378h Parallel Mode: PS/2 Diskette: Auto NIC: On MAC Address: 00B00080A59C Primary SCSI: On Channel A: SCSI Channel B: SCSI Secondary SCSI: On	To assign and enable a password, press the left- or right- arrow key, then type the password and press <Enter>. Repeat to verify. If the system beeps when you press a key, the key is illegal for password use. Press the <Esc> key to abort the password entry procedure. Pentium® III Xeon™ Processor Level 2 Cache: 256 KB Advanced System Memory: 128 MB ECC SDRAM Video Memory: 4 MB SDRAM Service Tag:
Tab, Shift-Tab change fields ←, → change values Alt-P next Esc exit Alt-B reboot	

If your system has RAID on motherboard (ROMB), Page 2 of the setup screen is as follows:

Dell Computer Corporation (www.dell.com)	
Page 2 of 2	System PowerEdge 4400/600 Setup BIOS Version: XXX
Keyboard Errors: Report Boot Sequence: Device List, Ctrl → System Password: Disabled by Jumper Setup Password: Disabled by Jumper Password Status: Unlocked ———— Integrated Devices ———— USB: On Mouse: On Serial Port 1: Auto Serial Port 2: Auto Parallel Port: 378h Parallel Mode: PS/2 Diskette: Auto NIC: On MAC Address: 00B00080A59C Onboard RAID: RAID Channel A: RAID Channel B: RAID Secondary SCSI: On	To assign and enable a password, press the left- or right- arrow key, then type the password and press <Enter>. Repeat to verify. If the system beeps when you press a key, the key is illegal for password use. Press the <Esc> key to abort the password entry procedure. Pentium® III Xeon™ Processor Level 2 Cache: 256 KB Advanced System Memory: 128 MB ECC SDRAM Video Memory: 4 MB SDRAM Service Tag:
Tab, Shift-Tab change fields ←, → change values Alt-P next Esc exit Alt-B reboot	

Dell Computer Corporation (www.dell.com)	
Device List	System PowerEdge 4400/600 Setup BIOS Version: XXX
Boot Device Priority: Diskette Drive A: Exclude from Boot Device Priority:	The DEVICE LIST contains devices that may be bootable. The system attempts to boot from the devices in the list as ordered. If you ESC or ALT-B from this menu, the displayed order becomes the boot selection. Ctrl-Ins moves items between "Boot Device Priority" and "Exclude from Boot Device Priority" only. PgDn next 1 of 2 PgUp prev
Device Controller Priority: System BIOS boot devices AIC-7899:00 SEAGATE ST34371W	Pentium® III Xeon™ Processor Level 2 Cache: 256 KB Advanced System Memory: 128 MB ECC SDRAM Video Memory: 4 MB SDRAM Service Tag:
Tab,Shift-Tab change fields ←,→ change values Alt-P next Esc exit Alt-E reboot	

System Setup Options

The following subsections explain in detail each of the options on the System Setup screens.

Time

Time resets the time on the computer's internal clock.

Time is kept in a 24-hour format (*hours:minutes:seconds*). To change the time, press the right-arrow key to increase the number in the highlighted field or press the left-arrow key to decrease the number. If you prefer, you can type numbers in each of the appropriate fields.

Date

Date resets the date on the computer's internal calendar.

Your system automatically displays the day of the week corresponding to the settings in the three fields that follow (*month, day-of-month, and year*).

To change the date, press the right-arrow key to increase the number in the highlighted field or press the left-arrow key to decrease the number. If you prefer, you can type numbers in the *month* and *day-of-month* fields.

Diskette Drive A

Diskette Drive A identifies the type of diskette drive installed in your computer. With the standard cabling configuration, **Diskette Drive A** (the boot diskette drive) is the 3.5-inch diskette drive installed in the top, externally accessible drive bay.

The option's settings always match the physical locations of the drives in your computer—the first drive listed on **Page 1** of the System Setup screens is the top drive in your computer.

The settings are:

- 1 3.5 Inch, 1.44 MB (default)
- 1 3.5 Inch, 720 KB
- 1 5.25 Inch, 360 KB
- 1 5.25 Inch, 1.2 MB
- 1 Not Installed

Diskette Drive B

Diskette Drive B identifies the type of diskette drive installed in your computer. With the standard cabling configuration, **Diskette Drive B** is the 3.5-inch diskette drive installed in the bottom, externally accessible drive bay.

The settings are:

- 1 3.5 Inch, 1.44 MB
- 1 3.5 Inch, 720 KB
- 1 5.25 Inch, 360 KB
- 1 5.25 Inch, 1.2 MB
- 1 Not Installed (default)

Speaker

Speaker determines whether the integrated speaker is **On** (the default) or **Off**. A change to this option takes effect immediately (rebooting the system is not required).

Num Lock

Num Lock determines whether your system boots with the Num Lock mode activated on 101- or 102-key keyboards (it does not apply to 84-key keyboards).

When **Num Lock** mode is activated, the rightmost bank of keys on your keyboard provides the mathematical and numeric functions shown at the tops of the keys. When **Num Lock** mode is turned off, these keys provide cursor-control functions according to the label on the bottom of each key.

OS Install Mode

The **OS Install Mode** determines the maximum amount of memory available to the operating system. **On** sets the maximum memory available to the the operating system to 256 megabytes (MB). **Off** (default) makes all of the system memory available to the operating system.

Fan Speed

The **Fan Speed** option has the following settings:

- 1 **Full Speed** (default)
- 1 **Noise Reduced**

System Alert

The **System Alert** option has the following settings:

- 1 **Fault** (default)
- 1 **Warning**

Processor Serial Number

Processor Serial Number enables or disables the processor serial number feature. This option has the following settings:

- 1 **Disabled** (default)
- 1 **Enabled**

Processor Core

Processor Core displays the internal microprocessor speed.

Processor Bus

Processor Bus displays the front side bus speed.

Processor 1 and Processor 2

Processor 1 and **Processor 2** display the stepping number of the processor in processor slot 1 or slot 2 (such as **C0**), if one is installed. If the stepping number is unknown, **Unknown** is displayed. If no processor is installed in this slot, **Not Installed** is displayed. This option has no user-selectable settings.

Keyboard Errors

Keyboard Errors enables or disables reporting of keyboard errors during the power-on self-test (POST), which is a series of tests that the system performs on the hardware each time you turn on the system.

This option is useful when applied to self-starting servers or host systems that have no permanently attached keyboard. In these situations, selecting **Do Not Report** suppresses all error messages relating to the keyboard or to the keyboard controller during POST. This setting does not affect the operation of the keyboard itself if a keyboard is attached to the computer.

Boot Sequence

Boot Sequence can be set to **Diskette First** (default), **Hard Disk Only**, or **Device List, Ctrl →**.

The term *boot* refers to the system's start-up procedure. When turned on, the system "bootstraps" itself into an operational state by loading into memory a small program, which in turn loads the necessary operating system. **Boot Sequence** tells the system where to look for the files that it needs to load. **Diskette First**

Selecting **Diskette First** causes the system to try booting from drive A first. If the system finds a diskette that is not bootable in the drive or finds a problem with the drive itself, it displays an error message. If it does not find a diskette in the drive, the system tries to boot from the hard-disk drive

(drive 0). If the hard-disk drive is not bootable, the system tries to boot from the Plug and Play network adapters in the order found.

Hard Disk Only

Selecting **Hard Disk Only** causes the system to attempt to boot first from the hard-disk drive and then from the Plug and Play network adapters in the order found.

Device List, Ctrl->

Selecting **Device List, Ctrl->** causes the system to attempt to boot from devices in the list shown on the **Device List** screen of the System Setup program. Pressing <Ctrl> and the right-arrow key simultaneously causes the **Device List** screen to appear.

System Password

System Password displays the current status of your system's password security feature and allows you to assign and verify a new password. No one can assign a new password unless the current status is **Not Enabled**, which is displayed in bright characters.

The settings for the **System Password** option are:

- 1 **Not Enabled** (default)
- 1 **Enabled**
- 1 **Disabled by Jumper** (jumper removed)

 *NOTE: See "[Using the System Password Feature](#)" for instructions on assigning a system password and using or changing an existing system password. See "[Disabling a Forgotten Password](#)" for instructions on disabling a forgotten system password.*

Setup Password

Setup Password lets you restrict access to your computer's System Setup program in the same way that you restrict access to your system with the system password feature. The settings are:

- 1 **Not Enabled** (default)
- 1 **Enabled**
- 1 **Disabled by Jumper** (jumper removed)

 *NOTE: See "[Using the Setup Password Feature](#)" for instructions on assigning a setup password and using or changing an existing setup password. See "[Disabling a Forgotten Password](#)" for instructions on disabling a forgotten setup password.*

Password Status

When **Setup Password** is set to **Enabled**, **Password Status** allows you to prevent the system password from being changed or disabled at system start-up.

To lock the system password, you must first assign a setup password in the **Setup Password** option and then change the **Password Status** option to **Locked**. In this state, the system password cannot be changed through the **System Password** option and cannot be disabled at system start-up by pressing <Ctrl><Enter>.

To unlock the system password, you must enter the setup password in the **Setup Password** option and then change the **Password Status** option to **Unlocked**. In this state, the system password can be disabled at system start-up by pressing <Ctrl><Enter> and then changed through the **System Password** option.

USB

USB enables or disables the system's Universal Serial Bus (USB) ports. Disabling the USB ports makes system resources available for other devices.

Mouse

Mouse enables or disables the system's integrated Personal System/2 (PS/2)-compatible mouse port. Disabling the mouse allows an expansion card to use IRQ12.

Serial Port 1 and Serial Port 2

Serial Port 1 and **Serial Port 2** configure the system's integrated serial ports. These options can be set to **Auto** (the default setting) to automatically configure a port, to a particular designation (**COM1** or **COM3** for **Serial Port 1**; **COM2** or **COM4** for **Serial Port 2**), or to **Off** to disable the port.

If you set a serial port to **Auto** and add an expansion card containing a port configured to the same designation, the system automatically remaps the integrated port to the next available port designation that shares the same interrupt request (IRQ) setting as follows:

- 1 COM1 (input/output [I/O] address 3F8h), which shares IRQ4 with COM3, is remapped to COM3 (I/O address 3E8h).
- 1 COM2 (I/O address 2F8h), which shares IRQ3 with COM4, is remapped to COM4 (I/O address 2E8h).

 **NOTE:** When two COM ports share an IRQ setting, you can use either port as necessary, but you may not be able to use them both at the same time. If the second port (COM3 or COM4) is also in use, the integrated port is turned off.

Parallel Port

Parallel Port configures the system's integrated parallel port. This option can be set to **378h** (the default), to alternate addresses **278h** or **3BCh**, or to **Off** to disable the port.

 **NOTE:** Do not set **Parallel Port** to **278h** if you have an Enhanced Capabilities Port (ECP) device connected to the port.

Parallel Mode

Parallel Mode controls whether the system's integrated parallel port acts as an AT-compatible (unidirectional) or PS/2-compatible (bidirectional) port.

Set this option according to the type of peripheral device that is connected to the parallel port. To determine the correct mode to use, see the documentation that came with the device.

Diskette

Diskette controls the operation of the system's integrated diskette drive controller.

With **Auto** (default) selected, the system turns off the integrated diskette drive controller when necessary to accommodate a controller card installed in an expansion slot.

With **Write Protect** selected, nothing can be written to diskette drives and tape drives using the system's integrated diskette drive controller. (The system can still read from the drives.) When this setting is selected, the **Auto** setting (whereby the system turns off the integrated diskette drive controller as necessary) is also in effect.

Selecting **Off** turns off the integrated diskette controller; this setting is used primarily for troubleshooting purposes.

NIC

NIC determines whether the system's integrated network interface controller (NIC) is **On** or **Off** (the default). Changes take effect after reboot.

MAC Address

The **MAC Address** field displays the address of the media access control (MAC) address used by the integrated NIC. This field has no user-selectable settings.

Primary SCSI and Secondary SCSI

Primary SCSI and **Secondary SCSI** turn the respective SCSI controller on or off. Selecting **On** (the default setting) enables the integrated PCI SCSI controller and scans the associated ROM. For the system to boot from a drive attached to the integrated SCSI controller, the drive must be enabled. Selecting **Off** causes the BIOS to mask the presence of a device.

Onboard RAID

When ROMB is detected, selections are **RAID**, **SCSI**, and **Off**. When **Onboard RAID** is set to **RAID**, **Channel A** displays **RAID** and **Channel B** can be set to **RAID** or **SCSI**. When **Onboard RAID** is set to **SCSI** or **Off**, **Channel A** and **Channel B** display **SCSI**.

NOTICE: To avoid possible data loss, back up all data on the hard-disk drives before changing the mode of operation of the integrated SCSI controller.

Channel A

Channel A displays the selections **RAID** or **SCSI**. When **RAID** is displayed, this channel supports RAID functionality. When **SCSI** is displayed, it functions as a SCSI channel.

Channel B

Channel B will display the selections **RAID** or **SCSI**. When **RAID** is displayed, this channel supports RAID functionality. When **SCSI** is displayed, it functions as a SCSI channel.

System Data Categories

The following categories, which are not selectable, display information about the system:

- 1 The processor line displays the microprocessor type and speed.
 - 1 **Level 2 Cache** displays the size of the cache (256 kilobytes [KB]). **Advanced** is displayed for a microprocessor with enhanced cache.
 - 1 **System Memory** indicates the entire amount of installed memory detected in your system, except for memory on Expanded Memory Specification (EMS) expansion cards. After adding memory, check this option to confirm that the new memory is installed correctly and is recognized by the system.
 - 1 **Video Memory** displays the amount of video memory detected in your system.
 - 1 **Service Tag** displays the system's five-character service tag number, which was programmed into NVRAM by Dell during the manufacturing process. Refer to this number during technical assistance or service calls. The service tag number is also accessed by certain Dell support software, including the diagnostics software.
-

Using the System Password Feature

NOTICE: The password features provide a basic level of security for the data on your system. However, they are not foolproof. If your data requires more security, it is your responsibility to obtain and use additional forms of protection, such as data encryption programs.

Your Dell system is shipped to you without the system password feature enabled. If system security is a concern, you should operate your system only with system password protection.

You can [assign a system password](#) whenever you use the System Setup program. After a system password is assigned, only those who know the password have full use of the system.

When the **System Password** option is set to **Enabled**, the computer system prompts you for the system password just after the system boots.

To change an existing system password, you must know the password (see "[Deleting or Changing an Existing System Password](#)"). If you assign and later forget a system password, you need to be able to remove the computer cover to change a jumper setting that disables the system password feature (see "[Disabling a Forgotten Password](#)"). Note that you erase the setup password at the same time.

NOTICE: If you leave your system running and unattended without having a system password assigned, or if you leave your computer unlocked so that someone can disable the password by changing a jumper setting, anyone can access the data stored on your hard-disk drive.

Assigning a System Password

Before you can assign a system password, you must enter the System Setup program and check the **System Password** option.

When a system password is assigned, the setting shown for the **System Password** option is **Enabled**. When the system password feature is disabled by a jumper setting on the system board, the setting shown is **Disabled by Jumper**. You cannot change or enter a new system password if either of these settings is displayed.

When no system password is assigned and the password jumper on the system board is in the enabled position (its default), the setting shown for the **System Password** option is **Not Enabled**. Only when this option is set to **Not Enabled** can you assign a system password, using the following procedure:

1. Verify that the **Password Status** option is set to **Unlocked**.

For instructions on changing the setting for **Password Status**, see "[Password Status](#)."

2. Highlight the **System Password** option, and then press the left- or right-arrow key.

The option heading changes to **Enter Password**, followed by an empty seven-character field in square brackets.

3. Type your new system password.

You can use up to seven characters in your password.

As you press each character key (or the spacebar key for a blank space), a placeholder appears in the field.

The password assignment operation recognizes keys by their location on the keyboard, without distinguishing between lowercase and uppercase characters. For example, if you have an *M* in your password, the system recognizes either *M* or *m* as correct.

Certain key combinations are not valid. If you enter one of these combinations, the speaker emits a beep.

To erase a character when entering your password, press the <Backspace> key or the left-arrow key.

 **NOTE:** To escape from the field without assigning a system password, press the <Tab> key or the <Shift><Tab> key combination to move to another field, or press the <Esc> key at any time prior to completing step 5.

4. Press <Enter>.

If the new system password is less than seven characters, the whole field fills with placeholders. Then the option heading changes to **Verify Password**, followed by another empty seven-character field in square brackets.

5. To confirm your password, type it a second time and press <Enter>.

The password setting changes to **Enabled**. Your system password is now set; you can exit the System Setup program and begin using your system. Note, however, that password protection does not take effect until you reboot the system by turning the system off and then on again.

Using Your System Password to Secure Your System

Whenever you turn on your system, reboot the system by pressing the <Ctrl><Alt> key combination, the following prompt appears on the screen when the **Password Status** option is set to **Unlocked**:

```
Type in the password and... -- press <ENTER> to leave password security enabled. -- press
<CTRL><ENTER> to disable password security. Enter password:
```

If the **Password Status** option is set to **Locked**, the following prompt appears:

```
Type the password and press <Enter>.
```

After you type the correct system password and press <Enter>, your system boots and you can use the keyboard or mouse to operate your system as usual.

 **NOTE:** If you have assigned a setup password (see "[Using the Setup Password Feature](#)"), the system accepts your setup password as an alternate system password.

If a wrong or incomplete system password is entered, the following message appears on the screen:

```
** Incorrect password. **
```

```
Enter password:
```

If an incorrect or incomplete system password is entered again, the same message appears on the screen.

The third and subsequent times an incorrect or incomplete system password is entered, the system displays the following message:

```
** Incorrect password. **
Number of unsuccessful password attempts: 3
System halted! Must power down.
```

The number of unsuccessful attempts made to enter the correct system password can alert you to an unauthorized person attempting to use your system.

Even after your system is turned off and on, the previous message is displayed each time an incorrect or incomplete system password is entered.

 **NOTE:** You can use the **Password Status** option in conjunction with **System Password** and **Setup Password** to further protect your system from unauthorized changes. For more information, see "[Password Status](#)."

Deleting or Changing an Existing System Password

To delete or change an existing system password, perform the following steps:

1. Enter the System Setup program and verify that the **Password Status** option is set to **Unlocked**.

Enter the System Setup program by pressing the <F2> key. Press the <Alt><p> key combination to move to Page 2 of the System Setup screens. For instructions on changing the setting for **Password Status**, see "[Password Status](#)."

2. Reboot your system to force it to prompt you for a system password.
3. When prompted, type the system password.
4. Press the <Ctrl><Enter> key combination to disable the existing system password, instead of pressing <Enter> to continue with the normal operation of your system.
5. Confirm that **Not Enabled** is displayed for the **System Password** option of the System Setup program.

If **Not Enabled** appears for the **System Password** option, the system password has been deleted. If you want to assign a new password, continue to step 6. If **Not Enabled** is not displayed for the **System Password** option, press the <Alt> key combination to reboot the system, and then repeat steps 3 through 5.

6. To assign a new password, follow the procedure in "[Assigning a System Password](#)."

Using the Setup Password Feature

Your Dell system is shipped to you without the setup password feature enabled. If system security is a concern, you should operate your system with setup password protection.

You can [assign a setup password](#) whenever you use the System Setup program. After a setup password is assigned, only those who know the

password have full use of the System Setup program.

To change an existing setup password, you must know the setup password (see "[Deleting or Changing an Existing Setup Password](#)"). If you assign and later forget a setup password, you cannot operate your system or change settings in the System Setup program until a trained service technician opens the computer chassis, changes the password jumper setting to disable the passwords, and erases the existing passwords. This procedure is described in Appendix B of the *Installation and Troubleshooting Guide*.

Assigning a Setup Password

A setup password can be assigned (or changed) only when the **Setup Password** option is set to **Not Enabled**. To assign a setup password, highlight the **Setup Password** option and press the left- or right-arrow key. The system prompts you to enter and verify the password. If a character is illegal for password use, the system emits a beep.

 **NOTES:** *The setup password can be the same as the system password.*

If the two passwords are different, the setup password can be used as an alternate system password. However, the system password cannot be used in place of the setup password.

After you verify the password, the **Setup Password** setting changes to **Enabled**. The next time you enter the System Setup program, the system prompts you for the setup password.

A change to the **Setup Password** option becomes effective immediately (rebooting the system is not required).

Operating With a Setup Password Enabled

If **Setup Password** is set to **Enabled**, you must enter the correct setup password before you can modify the majority of the System Setup options.

When you start the System Setup program, **Page 2** of the System Setup screens appears with the **Setup Password** option highlighted, prompting you to type the password.

If you do not enter the correct password in three tries, the system lets you view, but not modify, the System Setup screens—with the following exceptions:

- 1 You can still modify the **Date**, **Time**, **Processor Speed**, **Num Lock**, and **Speaker** options.
- 1 If **System Password** is not enabled and is not locked via the **Password Status** option, you can assign a system password (however, you cannot disable or change an existing system password).

 **NOTE:** *You can use the **Password Status** option in conjunction with **Setup Password** to protect the system password from unauthorized changes. For more information, see "[Password Status](#)."*

Deleting or Changing an Existing Setup Password

To delete or change an existing setup password, perform the following steps:

1. Enter the System Setup program.
2. Highlight the **Setup Password** option and press the left- or right-arrow key to delete the existing setup password.
The setting changes to **Not Enabled**.
3. If you want to assign a new setup password, perform the steps in "[Assigning a Setup Password](#)."

Disabling a Forgotten Password

If you forget your system or setup password, you cannot operate your system or change settings in the System Setup program until a trained service technician opens the computer chassis, changes the password jumper setting to disable the passwords, and erases the existing passwords. This procedure is described in Appendix B of the *Installation and Troubleshooting Guide*.

Responding to Error Messages

If an error message appears on your monitor screen while the system is booting, make a note of the message. Then, before entering the System Setup program, refer to "System Beep Codes" and "System Messages" in "Messages and Codes" in the *Installation and Troubleshooting Guide* for an explanation of the message and suggestions for correcting any errors. (An exception to this routine: It is normal to receive an error message the first time you boot your system after installing a memory upgrade. In that situation, do not refer to "System Beep Codes" and "System Messages." Instead, follow the instructions for performing a memory upgrade in "Adding Memory" in "Installing System Board Options" in the *Installation and Troubleshooting Guide*.)

If you are given an option of pressing either <F1> to continue or <F2> to run the System Setup program, press the <F2> key.

[Back to Contents Page](#)

Technical Specifications: Dell™ PowerEdge™ 4400 Systems User's Guide

[Microprocessor](#)

[Expansion Bus](#)

[Memory](#)

[Drives](#)

[Ports](#)

[Video](#)

[Power](#)

[Physical](#)

[Environmental](#)

Microprocessor

Microprocessor types	Dual Intel® Pentium® III Xeon™ microprocessors with a minimum internal operating frequency of 600 MHz
Front side bus	133 MHz
Internal cache	internal to microprocessor
Math coprocessor	internal to microprocessor

Expansion Bus

Bus type	PCI bus
Expansion slots	seven full-length dedicated PCI PCI7 for use with optional DRAC 2 card

Memory

DIMM sockets	72-bit wide 168-pin sockets
DIMM capacities	64-, 128-, 256-, or 512 MB registered SDRAM DIMMs; must be rated for 133-MHz operation and installed in equal pairs
Standard RAM (minimum)	128 MB
Maximum RAM	4 GB

Drives

Diskette drive	3.5-inch, 1.44-MB diskette drive included with standard system
Tape drive	20 GB and higher
SCSI hard-disk drives	formatted capacities ranging from 9 GB to 36 GB
SCSI devices	an internal SCSI backplane provides a physical connection, hot-plug capability with RAID controller, termination, and automatic configuration for the internal SCSI hard-disk drives; an integrated Adaptec Ultra 160/m AIC-7899 SCSI host adapter supporting up to ten SCSI hard-disk drives depending on the installed backplane
CD-ROM drive	integrated Adaptec AIC-7880 Ultra/Wide SCSI host adapter supporting up to three SCSI devices in externally accessible front bays implemented as Ultra/Narrow SCSI CD-ROM drive included with standard system

Ports

Externally accessible:	
Serial	two 9-pin connectors
Parallel (bidirectional)	25-pin connector
USB	two 4-pin connectors
RJ45	RJ45 connector for connection to internal embedded NIC (Intel 82559 10/100 Ethernet controller)
Video	15-pin connector
PS/2-style keyboard	6-pin mini-DIN
PS/2-compatible mouse	6-pin mini-DIN

Internally accessible:	
Ultra 160/m SCSI controller	two 68-pin connectors for internal or external SCSI drives
Ultra/Narrow SCSI controller	50-pin connector for internal CD-ROM or optional tape backup units
Diskette drive	34-pin connector for internal 3.5-inch diskette drive
Embedded 10/100 Ethernet controller	connected to external RJ45 connector
Embedded PowerEdge RAID controller (optional)	Intel i960® RM on system board; provides PCI-to-PCI bridge; two integrated SCSI channels reside on the secondary PCI bus; optional software and unbuffered, 64-MB or 128-MB SDRAM DIMM available; supports RAID 0, 1, 5, and 10

Video

Video type	ATI Rage IIC PCI video controller; VGA connector
Video memory (standard)	4 MB SDRAM

Power

AC power supply:	
Wattage	320 W per supply
Voltage	100 to 240 V at 60 Hz/230 V at 50 Hz
System battery	CR2032 3-V lithium coin cell

Physical

Rack Mount (7U):	
Height	30.5 cm (12 inches)
Width	44 cm (17.5 inches)
Depth	71.1 cm (28 inches)
Weight	52.2 kg (115 lb)
Tower Chassis:	
Height	44 cm (17.5 inches)
Width	30.5 cm (12 inches)
Depth	71.1 cm (28 inches)
Weight	52.2 kg (115 lb)

Environmental

Temperature:	
Operating	10° to 35°C (50° to 95°F)
Storage	-40° to 65°C (-40° to 149°F)
Relative humidity:	
Operating	8% to 80% (noncondensing) with a humidity gradation of 10% per hour
Storage	5% to 95% (noncondensing)
Maximum vibration:	
Operating	0.25 G (half-sine wave) at a sweep of 3 to 200 Hz for 15 minutes
Storage	0.5 G at 3 to 200 Hz for 15 minutes
Maximum shock:	
Operating	six consecutively executed shock pulses in the positive and negative x, y, and z axes

Storage (non-operational)	(one pulse on each side of the system) of 41 G for up to 2 ms six consecutively executed shock pulses in the positive and negative x, y, and z axes (one pulse on each side of the system) of 71 G for 2 ms
Altitude:	
Operating	-16 to 3048 m (-50 to 10,000 ft)
Storage	-16 to 10,600 m (-50 to 35,000 ft)

 NOTE: For the full name of an abbreviation or acronym used in this table, see the ["Glossary."](#)

[Back to Contents Page](#)

[Back to Contents Page](#)

Warranty, Return Policy, and Year 2000 Statement of Compliance: Dell™ PowerEdge™ 4400 Systems User's Guide

[Limited Three-Year Warranty \(U.S. Only\)](#)

["Total Satisfaction" Return Policy \(U.S. and Canada Only\)](#)

[Limited Three-Year Warranty \(Canada Only\)](#)

[Year 2000 Statement of Compliance for Dell-Branded Hardware Products](#)

Limited Three-Year Warranty (U.S. Only)

Dell Computer Corporation ("Dell") manufactures its hardware products from parts and components that are new or equivalent to new in accordance with industry-standard practices. Dell warrants that the hardware products it manufactures will be free from defects in materials and workmanship. The warranty term is three years beginning on the date of invoice, as described in the following text.

Damage due to shipping the products to you is covered under this warranty. Otherwise, this warranty does not cover damage due to external causes, including accident, abuse, misuse, problems with electrical power, servicing not authorized by Dell, usage not in accordance with product instructions, failure to perform required preventive maintenance, and problems caused by use of parts and components not supplied by Dell.

This warranty does not cover any items that are in one or more of the following categories: software; external devices (except as specifically noted); accessories or parts added to a Dell system after the system is shipped from Dell; accessories or parts added to a Dell system through Dell's system integration department; accessories or parts that are not installed in the Dell factory; or DellWareSM products. Monitors, keyboards, and mice that are Dell-branded or that are included on Dell's standard price list are covered under this warranty; all other monitors, keyboards, and mice (including those sold through the DellWare program) are not covered. Batteries for portable computers are covered only during the initial one-year period of this warranty.

Coverage During Year One

During the one-year period beginning on the invoice date, Dell will repair or replace products covered under this limited warranty that are returned to Dell's facility. To request warranty service, you must call Dell's Customer Technical Support within the warranty period. Refer to "Getting Help" in your *Installation and Troubleshooting Guide* to find the appropriate telephone number for obtaining customer assistance. If warranty service is required, Dell will issue a Return Material Authorization Number. You must ship the products back to Dell in their original or equivalent packaging, prepay shipping charges, and insure the shipment or accept the risk of loss or damage during shipment. Dell will ship the repaired or replacement products to you freight prepaid if you use an address in the continental U.S., where applicable. Shipments to other locations will be made freight collect.

 **NOTE:** Before you ship the product(s) to Dell, back up the data on the hard-disk drive(s) and any other storage device(s) in the product(s). Remove any removable media, such as diskettes, CDs, or PC Cards. Dell does not accept liability for lost data or software.

Dell owns all parts removed from repaired products. Dell uses new and reconditioned parts made by various manufacturers in performing warranty repairs and building replacement products. If Dell repairs or replaces a product, its warranty term is not extended.

Coverage During Years Two and Three

During the second and third years of this limited warranty, Dell will provide, on an exchange basis and subject to Dell's Exchange Policy in effect on the date of the exchange, replacement parts for the Dell hardware product(s) covered under this limited warranty when a part requires replacement. You must report each instance of hardware failure to Dell's Customer Technical Support in advance to obtain Dell's concurrence that a part should be replaced and to have Dell ship the replacement part. Dell will ship parts (freight prepaid) if you use an address in the continental U.S. or Canada, where applicable. Shipments to other locations will be made freight collect. Dell will include a prepaid shipping container with each replacement part for your use in returning the replaced part to Dell. Replacement parts are new or reconditioned. Dell may provide replacement parts made by various manufacturers when supplying parts to you. The warranty term for a replacement part is the remainder of the limited warranty term.

You will pay Dell for replacement parts if the replaced part is not returned to Dell. The process for returning replaced parts, and your obligation to pay for replacement parts if you do not return the replaced parts to Dell, will be in accordance with Dell's Exchange Policy in effect on the date of the exchange.

You accept full responsibility for your software and data. Dell is not required to advise or remind you of appropriate backup and other procedures.

General Provisions

THIS WARRANTY GIVES YOU SPECIFIC LEGAL RIGHTS WHICH VARY FROM STATE TO STATE (OR JURISDICTION TO JURISDICTION). DELL'S RESPONSIBILITY FOR MALFUNCTIONS AND DEFECTS IN HARDWARE IS LIMITED TO REPAIR AND REPLACEMENT AS SET FORTH IN THIS WARRANTY STATEMENT. ALL EXPRESS AND IMPLIED WARRANTIES FOR THE PRODUCT, INCLUDING BUT NOT LIMITED TO ANY IMPLIED WARRANTIES OF AND CONDITIONS OF MERCHANTABILITY AND FITNESS FOR A PARTICULAR PURPOSE, ARE LIMITED IN DURATION TO THE WARRANTY PERIOD SET FORTH ABOVE AND NO WARRANTIES, WHETHER EXPRESS OR IMPLIED, WILL APPLY AFTER SUCH PERIOD.

SOME STATES (OR JURISDICTIONS) DO NOT ALLOW LIMITATIONS ON HOW LONG AN IMPLIED WARRANTY LASTS, SO THE PRECEDING LIMITATION MAY NOT APPLY TO YOU.

DELL DOES NOT ACCEPT LIABILITY BEYOND THE REMEDIES SET FORTH IN THIS WARRANTY STATEMENT OR LIABILITY FOR

INCIDENTAL OR CONSEQUENTIAL DAMAGES, INCLUDING WITHOUT LIMITATION ANY LIABILITY FOR PRODUCTS NOT BEING AVAILABLE FOR USE OR FOR LOST DATA OR SOFTWARE.

SOME STATES (OR JURISDICTIONS) DO NOT ALLOW THE EXCLUSION OR LIMITATION OF INCIDENTAL OR CONSEQUENTIAL DAMAGES, SO THE PRECEDING EXCLUSION OR LIMITATION MAY NOT APPLY TO YOU.

These provisions apply to Dell's limited three-year warranty only. For provisions of any service contract covering your system, refer to your invoice or the separate service contract that you will receive.

If Dell elects to exchange a system or component, the exchange will be made in accordance with Dell's Exchange Policy in effect on the date of the exchange. In any instance in which Dell issues a Return Material Authorization Number, Dell must receive the product(s) for repair prior to the expiration of the warranty period in order for the repair(s) to be covered by the warranty.

 *NOTE: If you chose one of the available warranty and service options in place of the standard limited three-year warranty described in the preceding text, the option you chose will be listed on your invoice.*

Limited Three-Year Warranty (Canada Only)

Dell Computer Corporation ("Dell") manufactures its hardware products from parts and components that are new or equivalent to new in accordance with industry-standard practices. Dell warrants that the hardware products it manufactures will be free from defects in materials and workmanship. The warranty term is three years beginning on the date of invoice, as described in the following text.

Damage due to shipping the products to you is covered under this warranty. Otherwise, this warranty does not cover damage due to external causes, including accident, abuse, misuse, problems with electrical power, servicing not authorized by Dell, usage not in accordance with product instructions, failure to perform required preventive maintenance, and problems caused by use of parts and components not supplied by Dell.

This warranty does not cover any items that are in one or more of the following categories: software; external devices (except as specifically noted); accessories or parts added to a Dell system after the system is shipped from Dell; accessories or parts added to a Dell system through Dell's system integration department; accessories or parts that are not installed in the Dell factory; or DellWareSM products. Monitors, keyboards, and mice that are Dell-branded or that are included on Dell's standard price list are covered under this warranty; all other monitors, keyboards, and mice (including those sold through the DellWare program) are not covered. Batteries for portable computers are covered only during the initial one-year period of this warranty.

Coverage During Year One

During the one-year period beginning on the invoice date, Dell will repair or replace products covered under this limited warranty that are returned to Dell's facility. To request warranty service, you must call Dell's Customer Technical Support within the warranty period. Refer to "Getting Help" in your *Installation and Troubleshooting Guide* to find the appropriate telephone number for obtaining customer assistance. If warranty service is required, Dell will issue a Return Material Authorization Number. You must ship the products back to Dell in their original or equivalent packaging, prepay shipping charges, and insure the shipment or accept the risk of loss or damage during shipment. Dell will ship the repaired or replacement products to you freight prepaid if you use an address in Canada, where applicable. Shipments to other locations will be made freight collect.

 *NOTE: Before you ship the product(s) to Dell, back up the data on the hard-disk drive(s) and any other storage device(s) in the product(s). Remove any removable media, such as diskettes, CDs, or PC Cards. Dell does not accept liability for lost data or software.*

Dell owns all parts removed from repaired products. Dell uses new and reconditioned parts made by various manufacturers in performing warranty repairs and building replacement products. If Dell repairs or replaces a product, its warranty term is not extended.

Coverage During Years Two and Three

During the second and third years of this limited warranty, Dell will provide, on an exchange basis and subject to Dell's Exchange Policy in effect on the date of the exchange, replacement parts for the Dell hardware product(s) covered under this limited warranty when a part requires replacement. You must report each instance of hardware failure to Dell's Customer Technical Support in advance to obtain Dell's concurrence that a part should be replaced and to have Dell ship the replacement part. Dell will ship parts (freight prepaid) if you use an address in the continental U.S. or Canada, where applicable. Shipments to other locations will be made freight collect. Dell will include a prepaid shipping container with each replacement part for your use in returning the replaced part to Dell. Replacement parts are new or reconditioned. Dell may provide replacement parts made by various manufacturers when supplying parts to you. The warranty term for a replacement part is the remainder of the limited warranty term.

You will pay Dell for replacement parts if the replaced part is not returned to Dell. The process for returning replaced parts, and your obligation to pay for replacement parts if you do not return the replaced parts to Dell, will be in accordance with Dell's Exchange Policy in effect on the date of the exchange.

You accept full responsibility for your software and data. Dell is not required to advise or remind you of appropriate backup and other procedures.

General Provisions

DELL MAKES NO EXPRESS WARRANTIES OR CONDITIONS BEYOND THOSE STATED IN THIS WARRANTY STATEMENT. DELL DISCLAIMS ALL OTHER WARRANTIES AND CONDITIONS, EXPRESS OR IMPLIED, INCLUDING WITHOUT LIMITATION IMPLIED WARRANTIES AND CONDITIONS OF MERCHANTABILITY AND FITNESS FOR A PARTICULAR PURPOSE. SOME STATES (OR JURISDICTIONS) DO NOT ALLOW LIMITATIONS ON IMPLIED WARRANTIES OR CONDITIONS, SO THIS LIMITATION MAY NOT APPLY TO YOU.

DELL'S RESPONSIBILITY FOR MALFUNCTIONS AND DEFECTS IN HARDWARE IS LIMITED TO REPAIR AND REPLACEMENT AS SET FORTH IN THIS WARRANTY STATEMENT. THESE WARRANTIES GIVE YOU SPECIFIC LEGAL RIGHTS, AND YOU MAY ALSO HAVE

OTHER RIGHTS, WHICH VARY FROM STATE TO STATE (OR JURISDICTION TO JURISDICTION).

DELL DOES NOT ACCEPT LIABILITY BEYOND THE REMEDIES SET FORTH IN THIS WARRANTY STATEMENT OR LIABILITY FOR INCIDENTAL OR CONSEQUENTIAL DAMAGES, INCLUDING WITHOUT LIMITATION ANY LIABILITY FOR PRODUCTS NOT BEING AVAILABLE FOR USE OR FOR LOST DATA OR SOFTWARE.

SOME STATES (OR JURISDICTIONS) DO NOT ALLOW THE EXCLUSION OR LIMITATION OF INCIDENTAL OR CONSEQUENTIAL DAMAGES, SO THE PRECEDING EXCLUSION OR LIMITATION MAY NOT APPLY TO YOU.

These provisions apply to Dell's limited three-year warranty only. For provisions of any service contract covering your system, refer to your invoice or the separate service contract that you will receive.

If Dell elects to exchange a system or component, the exchange will be made in accordance with Dell's Exchange Policy in effect on the date of the exchange. In any instance in which Dell issues a Return Material Authorization Number, Dell must receive the product(s) for repair prior to the expiration of the warranty period in order for the repair(s) to be covered by the warranty.

 *NOTE: If you chose one of the available warranty and service options in place of the standard limited three-year warranty described in the preceding text, the option you chose will be listed on your invoice.*

"Total Satisfaction" Return Policy (U.S. and Canada Only)

If you are an end-user customer who bought new products directly from a Dell company, you may return them to Dell within 30 days of the date of invoice for a refund or credit of the product purchase price. If you are an end-user customer who bought reconditioned or refurbished products from a Dell company, you may return them to Dell within 14 days of the date of invoice for a refund or credit of the product purchase price. In either case, the refund or credit will not include any shipping and handling charges shown on your invoice. If you are an organization that bought the products under a written agreement with Dell, the agreement may contain different terms for the return of products than specified by this policy.

To return products, you must call Dell Customer Service to receive a Credit Return Authorization Number. Refer to "Getting Help" in your *Installation and Troubleshooting Guide* to find the appropriate telephone number for obtaining customer assistance. To expedite the processing of your refund or credit, Dell expects you to return the products to Dell in their original packaging within five days of the date that Dell issues the Credit Return Authorization Number. You must also prepay shipping charges and insure the shipment or accept the risk of loss or damage during shipment. You may return software for refund or credit only if the sealed package containing the diskette(s) or CD(s) is unopened. Returned products must be in as-new condition, and all of the manuals, diskette(s), CD(s), power cables, and other items included with a product must be returned with it. For customers who want to return, for refund or credit only, either applications software or an operating system that has been installed by Dell, the whole system must be returned, along with any media and documentation that may have been included in the original shipment.

This "Total Satisfaction" Return Policy does not apply to DellWare products, which may be returned under DellWare's then-current return policy. In addition, reconditioned parts purchased through Dell Spare Parts Sales in Canada are nonreturnable.

Year 2000 Statement of Compliance for Dell-Branded Hardware Products

Dell-branded hardware products shipped on or after January 1, 1997, are eligible to carry the "NSTL Hardware Tested Year 2000 Compliant" logo by virtue of formal testing with, and successful completion of, the National Software Testing Laboratories (NSTL) YMARK2000 test.* Dell will treat a failure to pass the YMARK2000 test as a covered event under Dell's warranty for the product, subject to the normal warranty limitations.** For a complete copy of Dell's warranty, see the product's documentation. Dell-branded hardware products will also recognize the year 2000 as a leap year.

*The YMARK2000 standard tests the ability of system hardware and firmware to support the transition to the year 2000 (and to recognize leap years, when appropriate, for years 2000 through 2009 inclusive) and not that of options, operating systems, or applications software. Dell-branded hardware products that pass the YMARK2000 test conform to BSI-DISC PD 2000-1.

** Except for this clarification of Dell's warranty for NSTL logo hardware, all other warranties, conditions and remedies, express or implied, relating to year 2000 readiness or compliance are disclaimed. To make a claim under this warranty for NSTL logo hardware, customers must contact Dell prior to January 1, 2001. To make a claim, write to:

Dell Computer Corporation
P.O. Box 149258
Austin, Texas 78714-9258
Attention: Year 2000

Despite a system's ability to pass the YMARK2000 test, actual rollover results in specific operating environments may vary depending on other factors including, but not limited to, other hardware, operating systems, and applications software.

Previous Products

For Dell-branded hardware products shipped prior to January 1, 1997, that have an upgradable basic input/output system (BIOS), Dell makes available a BIOS upgrade. Although these products may not have been tested under the YMARK2000 test, Dell believes that the hardware would pass the YMARK2000 test, provided the appropriate BIOS upgrade is properly loaded.

For Dell-branded hardware products that do not have an upgradable BIOS, Dell has made available, as a convenience to customers, the Dell Program Patch, a software utility designed to assist customers in managing the year 2000 rollover.

Software

Dell specifically excludes all non-Dell-developed software from this compliance statement. All software run on Dell-branded hardware products should be independently verified by customers to be year 2000-compliant.

The factory-installed software on this system is the current version provided by the software manufacturer and validated by Dell for installation. Dell recommends checking each software manufacturer's year 2000 Web site for updates to their products. Links to a number of these Web sites can be found at the Dell year 2000 Web sites.

Additional Information

For additional information on year 2000 compliance of Dell-branded hardware products, refer to the following Dell year 2000 Web sites, or contact a Dell customer service representative in your area:

- 1 <http://www.dell.com/year2000> (Americas)
 - 1 <http://www.dell.com/jp/year2000> (Japan)
 - 1 <http://www.euro.dell.com/year2000> (Europe)
 - 1 <http://www.dell.com/ap/year2000/index.htm> (Asia Pacific)
-

[Back to Contents Page](#)